

# JVC



CD RECEIVER  
RECEPTOR CON CD  
RECEPTEUR CD

ENGLISH

ESPAÑOL

FRANÇAIS

## KD-AR600/KD-SC500

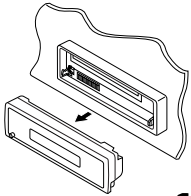

KD-AR600

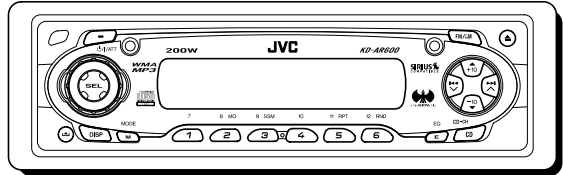
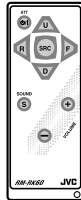

KD-SC500

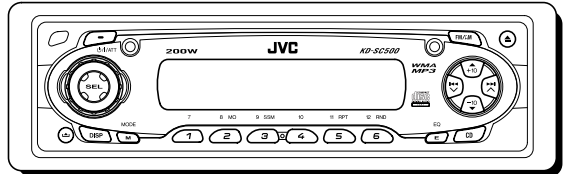
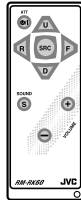

COMPACT  
**disc**  
DIGITAL AUDIO  
TEXT

SIRIUS  
COMPATIBLE

WMA  
MP3

- This unit is equipped with the display demonstration. To cancel it, see page 8.
- Esta unidad está equipada con demostración en la pantalla. Para cancelarla, consulte la página 8.
- Cet appareil est équipé d'une fonction de démonstration des affichages. Pour l'annuler, référez-vous à la page 8.

For installation and connections, refer to the separate manual.

Para la instalación y las conexiones, refiérase al manual separado.

Pour l'installation et les raccordements, se référer au manuel séparé.

## INSTRUCTIONS MANUAL DE INSTRUCCIONES MANUEL D'INSTRUCTIONS

### For customer Use:

Enter below the Model No. and Serial No. which are located on the top or bottom of the cabinet. Retain this information for future reference.

Model No. \_\_\_\_\_

Serial No. \_\_\_\_\_

GET0175-001A

[J]



**INFORMATION (For USA)**

This equipment has been tested and found to comply with the limits for a Class B digital device, pursuant to Part 15 of the FCC Rules. These limits are designed to provide reasonable protection against harmful interference in a residential installation. This equipment generates, uses, and can radiate radio frequency energy and, if not installed and used in accordance with the instructions, may cause harmful interference to radio communications. However, there is no guarantee that interference will not occur in a particular installation. If this equipment does cause harmful interference to radio or television reception, which can be determined by turning the equipment off and on, the user is encouraged to try to correct the interference by one or more of the following measures:

- Reorient or relocate the receiving antenna.
- Increase the separation between the equipment and receiver.
- Connect the equipment into an outlet on a circuit different from that to which the receiver is connected.
- Consult the dealer or an experienced radio/TV technician for help.

**IMPORTANT FOR LASER PRODUCTS**

1. CLASS 1 LASER PRODUCT
2. **CAUTION:** Do not open the top cover. There are no user serviceable parts inside the unit; leave all servicing to qualified service personnel.
3. **CAUTION:** Visible and invisible laser radiation when open and interlock failed or defeated. Avoid direct exposure to beam.

**How to reset your unit**

After detaching the control panel, press the reset button on the panel holder using a ball-point pen or a similar tool.

This will reset the built-in microcomputer.

**Note:**

*Your preset adjustments—such as preset channels or sound adjustments—will also be erased.*

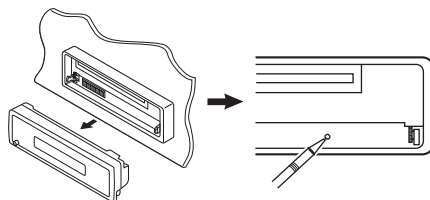
**BEFORE USE****\*For safety...**

- Do not raise the volume level too much, as this will block outside sounds, making driving dangerous.
- Stop the car before performing any complicated operations.

**\*Temperature inside the car...**

*If you have parked the car for a long time in hot or cold weather, wait until the temperature in the car becomes normal before operating the unit.*

Thank you for purchasing a JVC product. Please read all instructions carefully before operation, to ensure your complete understanding and to obtain the best possible performance from the unit.

# CONTENTS

How to reset your unit .....	2	<b>MP3/WMA OPERATIONS .....</b>	<b>18</b>
How to use the M MODE button .....	3	Playing a disc .....	18
<b>LOCATION OF THE BUTTONS .....</b>	<b>4</b>	Locating a file or particular portion on a disc .....	19
Control panel .....	4	Selecting playback modes .....	21
Remote controller .....	5	<b>SOUND ADJUSTMENTS .....</b>	<b>23</b>
Preparing the remote controller .....	6	Selecting preset sound modes (C-EQ: custom equalizer) .....	23
<b>BASIC OPERATIONS .....</b>	<b>7</b>	Adjusting the sound .....	24
Turning on the power .....	7	<b>OTHER MAIN FUNCTIONS .....</b>	<b>25</b>
Canceling the display demonstration .....	8	Changing the general settings (PSM) .....	25
Setting the clock .....	9	Assigning names to the sources .....	29
<b>RADIO OPERATIONS .....</b>	<b>10</b>	Changing the standard plate .....	30
Listening to the radio .....	10	Detaching the control panel .....	32
Storing stations in memory .....	11	<b>CD CHANGER OPERATIONS .....</b>	<b>33</b>
Tuning in to a preset station .....	12	(Only for KD-AR600)	
<b>CD OPERATIONS .....</b>	<b>13</b>	Playing discs .....	33
Playing a CD .....	13	Selecting the playback modes .....	36
Locating a track or a particular portion on a CD .....	14	<b>EXTERNAL COMPONENT OPERATIONS ...</b>	<b>37</b>
Selecting CD playback modes .....	15	(Only for KD-AR600)	
Playing a CD Text .....	16	Playing an external component .....	37
Prohibiting disc ejection .....	16	<b>TROUBLESHOOTING .....</b>	<b>38</b>
<b>MP3/WMA INTRODUCTION .....</b>	<b>17</b>	<b>MAINTENANCE .....</b>	<b>41</b>
What are MP3/WMA? .....	17	Handling discs .....	41
How are MP3/WMA files recorded and played back? .....	17	<b>SPECIFICATIONS .....</b>	<b>42</b>

## How to use the M MODE button

If you press M MODE, the unit goes into functions mode, then the number buttons and ▲/▼ buttons work as different function buttons.

Ex.: When number button 2 works as MO (monaural) button.

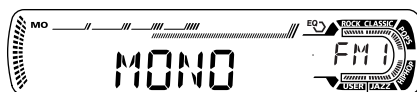
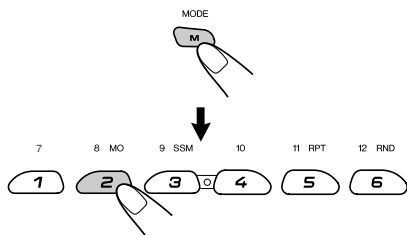

Time countdown indicator

To use these buttons for original functions again after pressing M MODE, wait for 5 seconds without pressing any of these buttons until the functions mode is cleared.

- Pressing M MODE again also clears the functions mode.



# LOCATION OF THE BUTTONS

ENGLISH

## Control panel

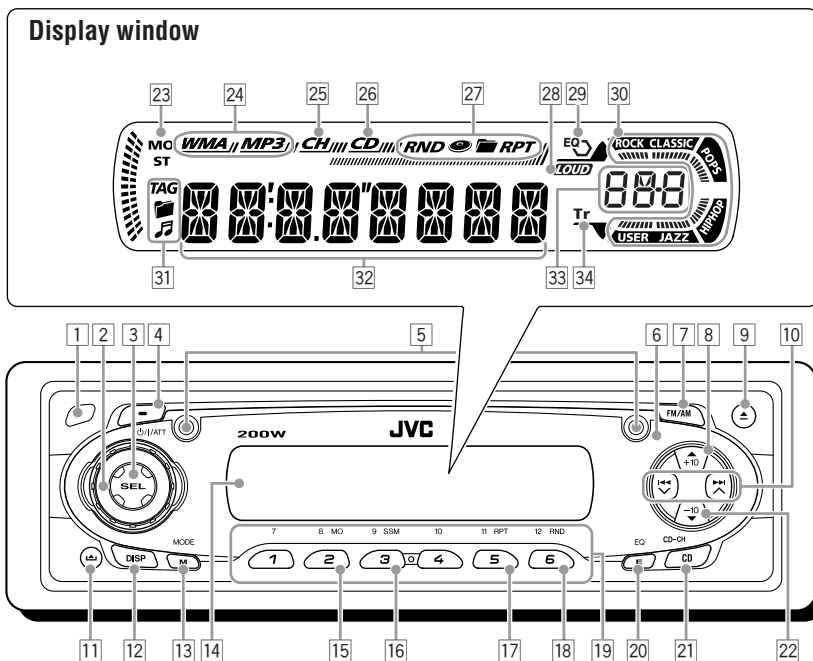

- 1 Remote sensor
- 2 Control dial
- 3 SEL (select) button
- 4  $\Phi$ /I/ATT (standby/on/attenuator) button
- 5 Screw - M2 x 5 mm (M2 x 1/4")
- 6 Plate cover and standard plate
- 7 FM/AM button
- 8  $\blacktriangle$  (up) button  
+10 button
- 9  $\blacktriangle$  (eject) button
- 10  $\lll$   $\ggg$   $\blacktriangleright$   $\blacktriangleleft$  buttons
- 11  $\square$  (control panel release) button
- 12 DISP (display) button
- 13 M MODE button
- 14 Display window
- 15 MO (monaural) button
- 16 SSM (strong-station sequential memory) button
- 17 RPT (repeat) button
- 18 RND (random) button
- 19 Number buttons
- 20 E EQ (equalizer) button
- 21 CD CD-CH (CD changer) button (KD-AR600)  
CD button (KD-SC500)
- 22  $\blacktriangledown$  (down) button  
-10 button

## Display window

- 23 Tuner reception indicators—MO (monaural), ST (stereo)
- 24 Disc type indicators—WMA, MP3
- 25 CH (CD changer) indicator (only for KD-AR600)
- 26 CD indicator
- 27 Playback mode/item indicators—RND (random),  $\circ$  (disc),  $\square$  (folder), RPT (repeat)
- 28 LOUD (loudness) indicator
- 29 EQ (equalizer) indicator
- 30 Sound mode (C-EQ: custom equalizer) indicators—ROCK, CLASSIC, POPS, HIP HOP, JAZZ, USER
  - *also works as level meter during play if the level meter is activated (see page 27).*
- 31 Disc information indicators—TAG (ID3 Tag),  $\square$  (folder),  $\square$  (track/file)
- 32 Main display
- 33 Source display  
Volume level indicator
- 34 Tr (track) indicator



## Remote controller

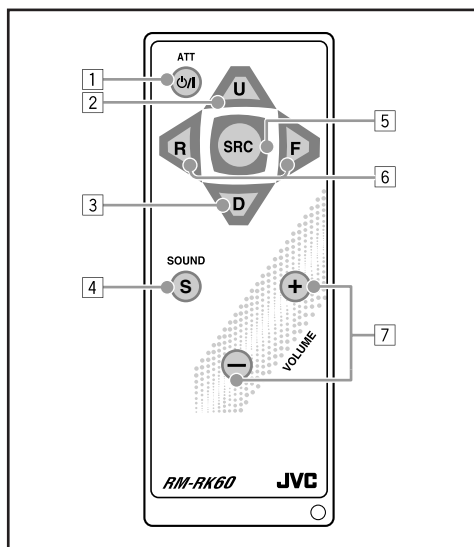

- 1 • Turns on the unit if pressed when the unit is turned off.
  - Turns off the unit if pressed and held until “SEE YOU” appears on the display.
  - Drops the volume level in a moment if pressed briefly.  
Press again to resume the volume.
- 2 • Selects the band while listening to the radio. Each time you press the button, the band changes.
  - Skips to the first file of the next folder while listening to an MP3 or a WMA disc. Each time you press the button, you can move to the next folder and start playing the first file.
  - While playing an MP3 disc on an MP3-compatible CD changer (only for KD-AR600);
    - Skips to the next disc if pressed briefly.
    - Skips to the next folder if pressed and held.

**Note:** While playing a CD on a CD changer, this always skips to the next disc.

- 3 • Selects the preset stations while listening to the radio. Each time you press the button, the preset station number increases, and the selected station is tuned in.
  - Skips to the first file of the previous folder while listening to an MP3 or a WMA disc. Each time you press the button, you can move to the previous folder and start playing the first file.
  - While playing an MP3 disc on an MP3-compatible CD changer (only for KD-AR600);
    - Skips to the previous disc if pressed briefly.
    - Skips to the previous folder if pressed and held.

**Note:** While playing a CD on a CD changer, this always skips to the previous disc.

- 4 • Selects the sound mode (C-EQ: custom equalizer). Each time you press the button, the sound mode (C-EQ) changes.
- 5 • Selects the source. Each time you press the button, the source changes.
- 6 • Searches for stations while listening to the radio.
  - Fast-forwards or reverses the track/file if pressed and held while listening to a disc.
  - Skips to the beginning of the next track/file or goes back to the beginning of the current (or previous) tracks/files if pressed briefly while listening to a disc.
- 7 • Functions the same as the control dial on the main unit.

**Note:** These buttons do not function for the preferred setting mode adjustment.



## Preparing the remote controller

Before using the remote controller:

- Aim the remote controller directly at the remote sensor on the main unit. Make sure there is no obstacle in between.

Remote sensor

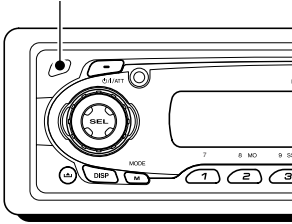

- Do not expose the remote sensor to strong light (direct sunlight or artificial lighting).

### Installing the battery

When the controllable range or effectiveness of the remote controller decreases, replace the battery.

#### 1. Remove the battery holder.

- 1) Push out the battery holder in the direction indicated by the arrow using a ball-point pen or a similar tool.
- 2) Remove the battery holder.

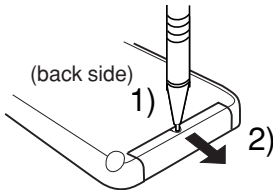

#### 2. Place the battery.

Slide the battery into the holder with the + side facing upwards so that the battery is fixed in the holder.

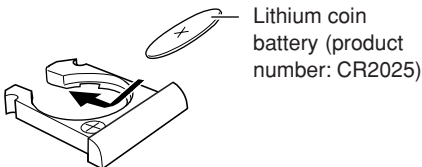

#### 3. Return the battery holder.

Insert again the battery holder by pushing it until you hear a clicking sound.

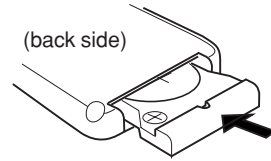

#### WARNING:

- Store the battery in a place where children cannot reach.  
*If a child accidentally swallows the battery, consult a doctor immediately.*
- Do not recharge, short, disassemble, or heat the battery or dispose of it in a fire.  
*Doing any of these things may cause the battery to give off heat, crack, or start a fire.*
- Do not leave the battery with other metallic materials.  
*Doing this may cause the battery to give off heat, crack, or start a fire.*
- When throwing away or saving the battery, wrap it in tape and insulate; otherwise, the battery may start to give off heat, crack, or start a fire.
- Do not poke the battery with tweezers or similar tools.  
*Doing this may cause the battery to give off heat, crack, or start a fire.*

#### CAUTION:

**DO NOT** leave the remote controller in a place (such as dashboards) exposed to direct sunlight for a long time. Otherwise, it may be damaged.

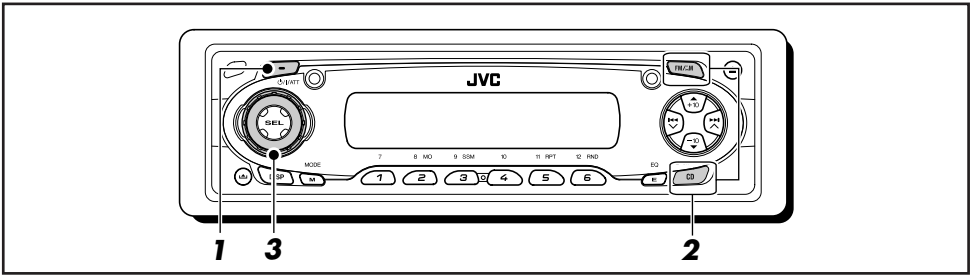

## Turning on the power

### 1 Turn on the power.

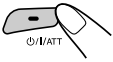

#### Note on One-Touch Operation:

When you select a source in step 2 below, the power automatically comes on. You do not have to press this button to turn on the power.

### 2 Select the source.

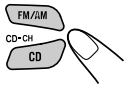

(For KD-AR600)

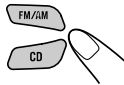

(For KD-SC500)

To operate the tuner (FM or AM), see pages 10 – 12.

To play a CD, see pages 13 – 16.

To play an MP3/WMA disc, see pages 18 – 22.

To operate the CD changer (only for KD-AR600), see pages 33 – 36.

To operate the external component (only for KD-AR600) (LINE IN or SIRIUS), see page 37.

### 3 Adjust the volume.

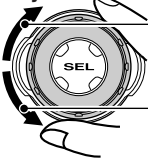

To increase the volume

To decrease the volume

Volume level indicator

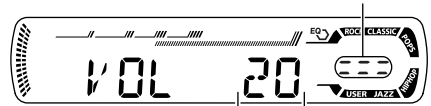

Volume level appears.

### 4 Adjust the sound as you want. (See pages 23 and 24.)

#### To drop the volume in a moment

Press I/ATT briefly while listening to any source. “ATT” starts flashing on the display, and the volume level will drop in a moment.

To resume the previous volume level, press the button briefly again.

- If you turn the control dial, you can also restore the sound.

#### To turn off the power

Press and hold I/ATT for more than one second.

“SEE YOU” appears, then the unit turns off.

- **If you turn off the power while listening to a disc**, disc play will start from where playback has been stopped previously, next time you turn on the power.

#### CAUTION on Volume Setting:

Discs produce very little noise compared with other sources. If the volume level is adjusted for the tuner, for example, the speakers may be damaged by the sudden increase in the output level. Therefore, lower the volume before playing a disc and adjust it as required during playback.

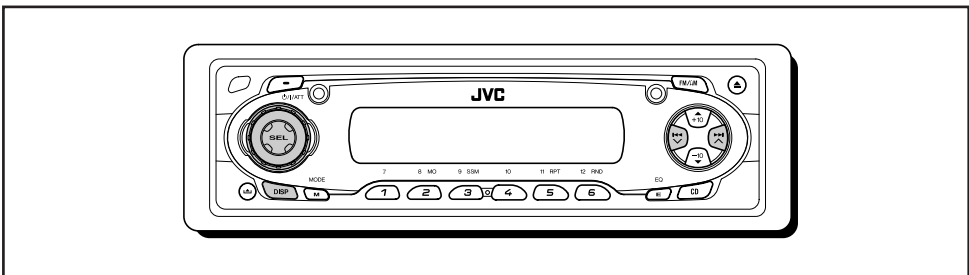

## Canceling the display demonstration

When shipped from the factory, display demonstration has been activated, and starts automatically when no operations are done for about 20 seconds.

- It is recommended to cancel the display demonstration before you use the unit for the first time.

To cancel the display demonstration, follow the procedure below:

- 1 Press and hold SEL (select) for more than 2 seconds so that one of the PSM items appears on the display. (PSM: see pages 25 and 26.)**



- 2 Select "DEMO" if not shown on the display.**

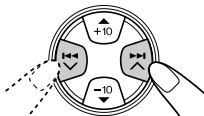

- 3 Select "DEMO OFF."**



DEMO OFF ↔ DEMO ON

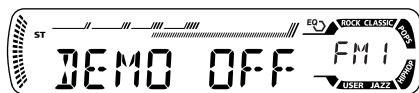

- 4 Finish the setting.**



To activate the display demonstration, repeat the same procedure and select "DEMO ON" in step 3.





# Setting the clock

**1** Press and hold SEL (select) for more than 2 seconds so that one of the PSM items appears on the display. (PSM: see pages 25 and 26.)



**2** Set the hour.

1 Select "CLOCK H" (hour) if not shown on the display.

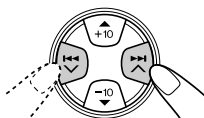

2 Adjust the hour.



**3** Set the minute.

1 Select "CLOCK M" (minute).

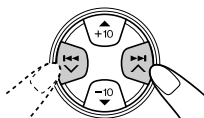

2 Adjust the minute.

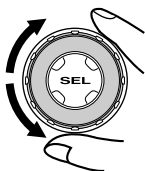

**4** Finish the setting.



To check the current clock time or change the display mode



Press DISP (display) repeatedly. Each time you press the button, the display changes as follows:

• During tuner operation:



• During disc operation:

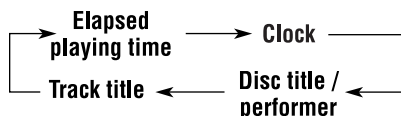

**Notes:**

- If a name has been assigned to a station, it will be shown instead of "NO NAME"
- While playing a conventional CD, "NO NAME" appears for the disc title/performer and the track title.
- For indication change while playing a CD Text or an MP3/WMA disc, see also pages 16 and 19.

• During external component operation: (only for KD-AR600)

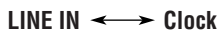

• During SIRIUS operation: (only for KD-AR600)

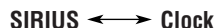

• During power off:

The power turns on and the clock time is shown for 5 seconds, then the power turns off.



# RADIO OPERATIONS

ENGLISH

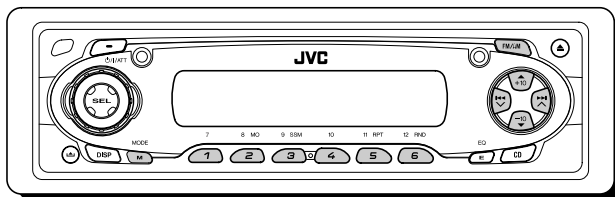

## Listening to the radio

You can use either automatic searching or manual searching to tune in to a particular station.

### Searching a station automatically: Auto search

#### 1 Select the band (FM1 – 3, AM).



Each time you press the button, the band changes as follows:

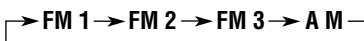

Lights up when receiving an FM stereo broadcast with sufficient signal strength.

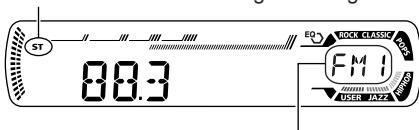

Selected band appears.

#### Note:

This receiver has three FM bands (FM1, FM2, FM3). You can use any one of them to listen to an FM broadcast.

#### 2 Start searching for a station.

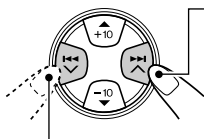

To search stations of higher frequencies

To search stations of lower frequencies

When a station is received, searching stops.

To stop searching before a station is received, press the same button you have pressed for searching.

### Searching a station manually: Manual search

#### 1 Select the band (FM1 – 3, AM).



Each time you press the button, the band changes as follows:

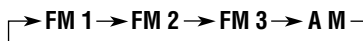

#### Note:

This receiver has three FM bands (FM1, FM2, FM3). You can use any one of them to listen to an FM broadcast.

#### 2 Press and hold **▶▶** **▲** or **◀◀** **▼** until "M" (manual) starts flashing on the display.

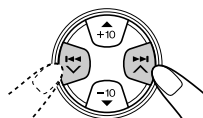

### 3 Tune in to a station you want while “M” (manual) is flashing.

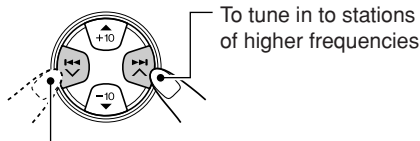

To tune in to stations of lower frequencies

- If you release your finger from the button, the manual mode will automatically turn off after 5 seconds.
- If you hold down the button, the frequency keeps changing (in 200 kHz intervals for FM and 10 kHz for AM) until you release the button.

### When an FM stereo broadcast is hard to receive:

**1** Press M MODE to enter the functions mode while listening to an FM stereo broadcast.



**2** Press MO (monaural), while “MODE” is still flashing on the display, so that the “MONO” appears on the display. Each time you press the button, monaural mode turns on and off alternately.

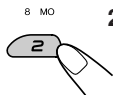

MO (monaural) indicator

When the MO indicator is lit on the display, the sound you hear becomes monaural but the reception will be improved.

## Storing stations in memory

You can use one of the following two methods to store broadcasting stations in memory.

- Automatic preset of FM stations: SSM (Strong-station Sequential Memory)
- Manual preset of both FM and AM stations

### FM station automatic preset: SSM

You can preset 6 local FM stations in each FM band (FM1, FM2, and FM3).

#### 1 Select the FM band (FM1 – 3) you want to store FM stations into.

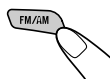

Each time you press the button, the band changes as follows:

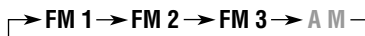

#### 2 Press M MODE to enter the functions mode.



#### 3 Press and hold SSM for about 2 seconds.

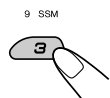

SSM flashes, then disappears when automatic preset is over.

Local FM stations with the strongest signals are searched and stored automatically in the band number you have selected (FM1, FM2, or FM3). These stations are preset in the number buttons—No.1 (lowest frequency) to No.6 (highest frequency).

When automatic preset is over, the station stored in number button 1 will be automatically tuned in.



### Manual preset

You can preset up to 6 stations in each band (FM1, FM2, FM3, and AM) manually.

Ex.: Storing an FM station of 92.5 MHz into the preset number 1 of the FM1 band.

#### 1 Select the band (FM1 – 3, AM) you want to store stations into (in this example, FM1).

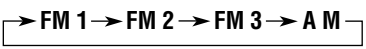
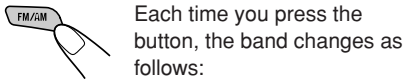

#### 2 Tune in to a station (in this example, of 92.5 MHz).

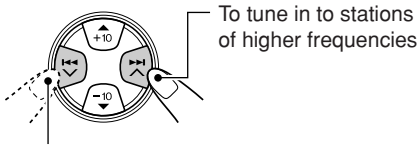

To tune in to stations of lower frequencies

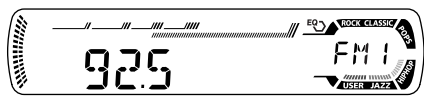

#### 3 Press and hold the number button (in this example, 1) for more than 2 seconds.

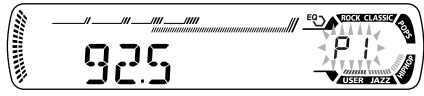
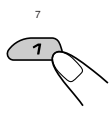

Preset number flashes for a few seconds

#### 4 Repeat the above procedure to store other stations into other preset numbers.

##### Notes:

- A previously preset station is erased when a new station is stored in the same preset number.
- Preset stations are erased when the power supply to the memory circuit is interrupted (for example, during battery replacement). If this occurs, preset the stations again.

### Tuning in to a preset station

You can easily tune in to a preset station. Remember that you must store stations first. If you have not stored them yet, see "Storing stations in memory" on pages 11 and 12.

#### 1 Select the band (FM1 – 3, AM).

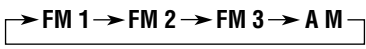
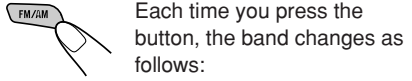

#### 2 Select the number (1 – 6) for the preset station you want.

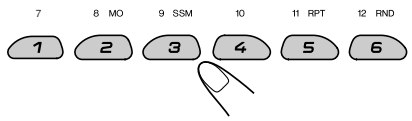

##### Note:

You can also use the ▲ (up) or ▼ (down) button on the unit to select the next or previous preset stations. Each time you press the ▲ (up) or ▼ (down) button, the next or previous preset station is tuned in.

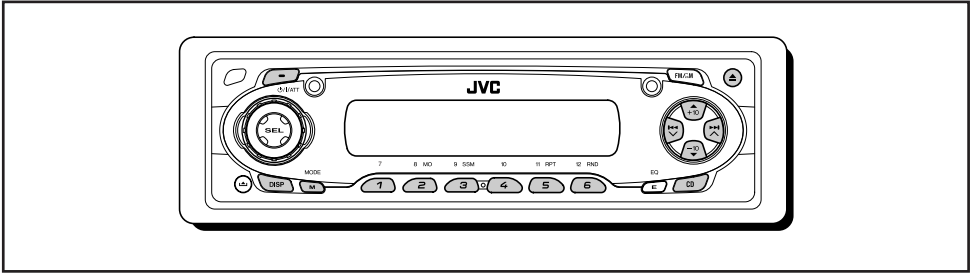

Refer "MP3/WMA OPERATIONS" on pages 18 to 22 for operating MP3/WMA discs.

The display changes to show the following:

## Playing a CD

### 1 Open the control panel.

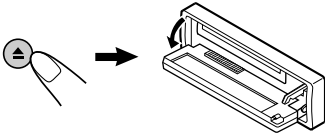

**Note:**

When a CD is already in the loading slot, pressing CD turns on the unit and starts playback automatically.

### 2 Insert a CD into the loading slot.

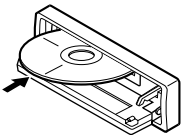

The unit turns on, draws the CD and starts playback automatically.

### 3 Close the control panel by hand.

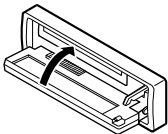

All tracks will be played repeatedly until you stop playback.

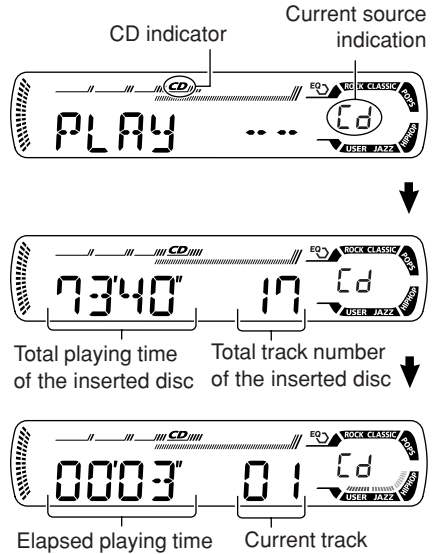

**Notes:**

- When a CD is inserted upside down, the CD automatically ejects (if the control panel is open). If the control panel is closed, the source changes to the tuner, "PLEASE" and "EJECT" appear alternately on the display.
- If there is no CD in the loading slot, you cannot select CD as the source. "NO DISC" appears on the display.
- If the disc is a CD Text, disc title/performer and then track title will automatically appear.



## To stop play and eject the CD

Press **▲**.

CD play stops and the control panel flips down. The CD automatically ejects from the loading slot. The source changes to the previously selected source.

- If you change the source, CD play also stops (without ejecting the CD).

Next time you select “CD” as the source, CD play starts from where playback has been stopped previously.

### Notes:

- If the ejected disc is not removed for about 15 seconds, the disc is automatically inserted again into the loading slot to protect it from dust. (Disc play will not start this time.)
- You can eject the disc even when the unit is turned off.

## Locating a track or a particular portion on a CD

### To fast-forward or reverse the track

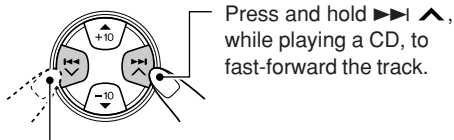

Press and hold <<<< ▼, while playing a CD, to reverse the track.

### To go to the next or previous tracks

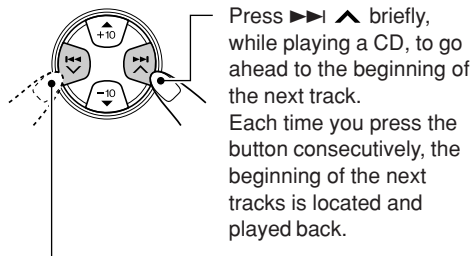

Press <<<< ▼ briefly, while playing a CD, to go back to the beginning of the current track. Each time you press the button consecutively, the beginning of the previous tracks is located and played back.

## To go to a particular track directly

Press the number button corresponding to the track number to start its playback.

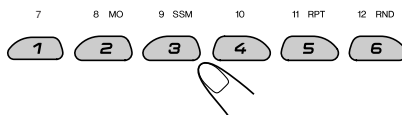

- To select a track number from 1 – 6: Press 1 (7) – 6 (12) briefly.
- To select a track number from 7 – 12: Press and hold 1 (7) – 6 (12) for more than one second.

## To go to a track quickly (+10 and -10 buttons)

- 1 Press M MODE to enter the functions mode while playing a CD.



- 2 Press +10 or -10.

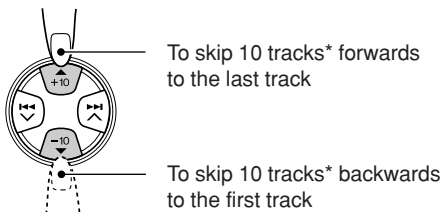

\* The first time you press +10 or -10 button, the track skips to the nearest higher or lower track with a track number of multiple ten (ex. 10th, 20th, 30th).

Then each time you press the button, you can skip 10 tracks (see “How to use the +10 and -10 buttons” on page 15).

- After the last track, the first track will be selected, and vice versa.



### How to use the +10 and -10 buttons

- Ex. 1: To select track number 32 while playing track number 6

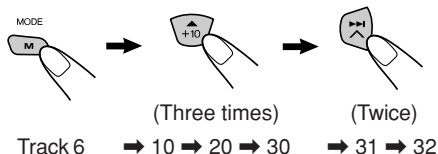

- Ex. 2: To select track number 8 while playing track number 36

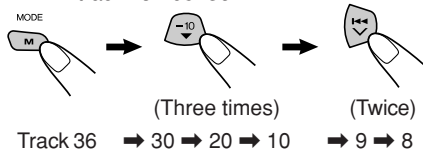

### To play back tracks repeatedly (Track Repeat Play)

You can play back the current track repeatedly.

- 1 Press M MODE to enter the functions mode while playing a CD.



- 2 Press RPT (repeat), while "MODE" is still flashing on the display, so that the "TRK RPT" appears on the display.

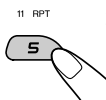

Each time you press the button, track repeat play mode turns on and off alternately.

RPT indicator



When track repeat play is turned on, the RPT indicator lights up on the display. The current track starts playing repeatedly.

## Selecting CD playback modes

### To play back tracks at random (Disc Random Play)

You can play back all tracks on the CD at random.

- 1 Press M MODE to enter the functions mode while playing a CD.



- 2 Press RND (random), while "MODE" is still flashing on the display, so that "DISC RND" appears on the display. Each time you press the button, disc random play mode turns on and off alternately.

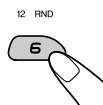

RND and (disc) indicators



When disc random play is turned on, the RND and (disc) indicators light up on the display. A track randomly selected starts playing.



## Playing a CD Text

In a CD Text, some information about the disc (its disc title, performer, and track title) is recorded. This CD Text information will be shown automatically when you play a CD Text.

### To change the CD Text information manually, select text display mode while playing a CD Text.



Press DISP (display) repeatedly. Each time you press the button, the display changes as follows:

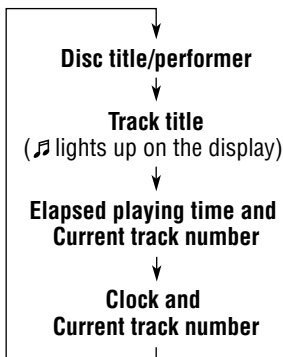

#### Notes:

- The display shows up to 8 characters at a time and scrolls if there are more than 8 characters. See also “To select the scroll mode—SCROLL” on page 28. Some characters or symbols will not be shown (and be blanked) on the display. (Ex. “ABC&!d#” ⇒ “ABCA D ”)
- When you press DISP (display) while playing a conventional CD, “NO NAME” appears for the disc title/performer and the track title.
- When track title is shown, the **TR** indicator and current track number also appear on the right side of the display.

## Prohibiting disc ejection

You can prohibit disc ejection and can lock a disc in the loading slot.

### While pressing CD, press and hold $\phi$ /I/ATT for more than 2 seconds.

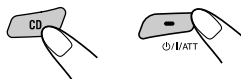

“NO EJECT” flashes on the display for about 5 seconds, and the disc is locked and cannot be ejected.



### To cancel the prohibition and unlock the disc

While pressing CD, press and hold  $\phi$ /I/ATT again for more than 2 seconds.

“EJECT OK” flashes on the display for about 5 seconds, and the disc is unlocked.





## What are MP3/WMA?

MP3 is an abbreviation of Motion Picture Experts Group (or MPEG) Audio Layer 3. MP3 is simply a file format with a data compression ratio of 1:10 (128 Kbps\*).

\* *Bit rate is the average number of bits that one second of audio data will consume. The unit used is Kbps. To get a better audio quality, choose a higher bit rate. The most popular bit rate for encoding is 128 Kbps.*

WMA (Windows Media® Audio) is the digital audio compression format developed by Microsoft Corporation.

- For details information about the MP3/WMA discs, refer to “A Guide to MP3/WMA” (separate volume).

## Compatible with ID3 Tag

Extra information data such as album title, performer name, song title, recording year, music genre and a brief comment can be stored within an MP3/WMA file.

This unit can show both ID3v1 (Version 1) and ID3v2 (Version 2) tags on the display. (See page 19.)

- Some characters cannot be shown correctly.
- If both ID3v1 and ID3v2 are recorded on a disc, ID3v2 information will be shown.

## How are MP3/WMA files recorded and played back?

MP3/WMA “files (tracks)” can be recorded in “folders”—in PC terminology.

During recording, the files and folders can be arranged in a way similar to arranging files and folders of computer data.

“Root” is similar to the root of a tree. Every file and folder can be linked to and be accessed from the root.

The illustration below shows an example of how MP3/WMA files are recorded on a CD-R or CD-RW, how they are played back, and how they are searched for on this unit.

### Notes:

- This unit cannot read or play an MP3 file without the extension code <.mp3> and a WMA track without the extension code <.wma>.
- This unit is not compatible with MP3 files encoded with Layer 1 and Layer 2 formats.
- This unit is not compatible with WMA files which are not based upon Windows Media® Audio.
- This unit is not compatible with Playlist\*\*.

\*\* A playlist is a simple text file, used on a PC, which enables users to make their own playback order without physically rearranging the files.

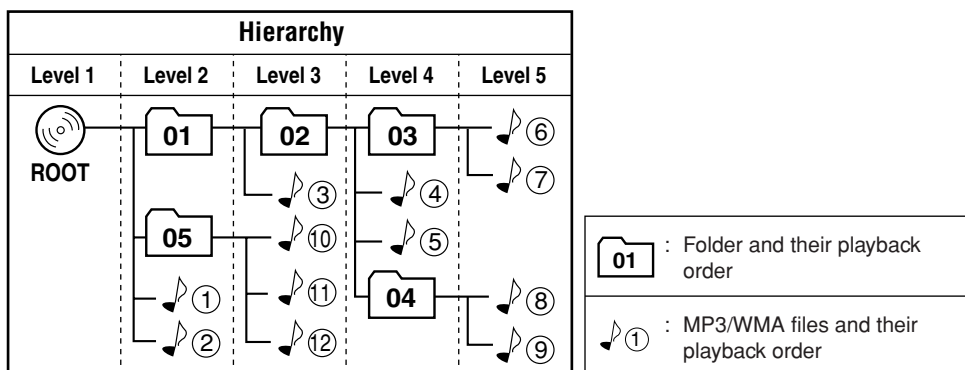

• Microsoft and Windows Media are either registered trademarks or trademarks of Microsoft Corporation in the United States and/or other countries.

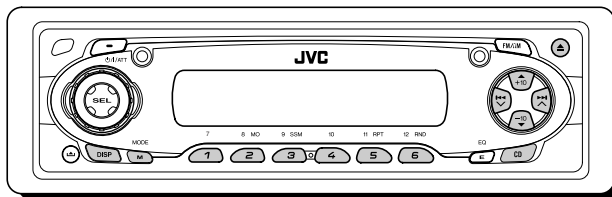

Refer also to “CD OPERATIONS” on pages 13 to 16.

The display changes to show the following:

## Playing a disc

### 1 Open the control panel.

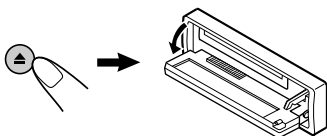

**Note on One-Touch Operation:**

When a disc is already in the loading slot, pressing CD turns on the unit and starts playback automatically.

### 2 Insert a disc into the loading slot.

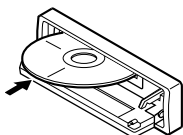

The unit turns on, draws the disc and starts playback automatically.

### 3 Close the control panel by hand.

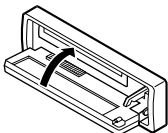

All files will be played repeatedly until you stop playback.

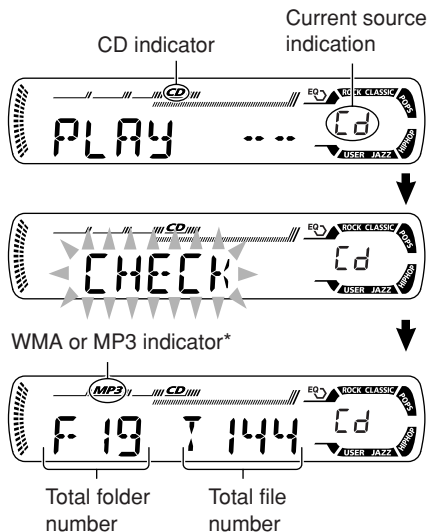

Ex.: When the disc contains 19 folders and 144 MP3/WMA files

\* WMA or MP3 indicator lights up depending on the first detected file.

**Notes:**

- MP3/WMA discs require a longer readout time. (It differs due to the complexity of the folder/file configuration.)
- When playback starts, folder and file names (or ID3 tags) will automatically appears. (See also page 19.)
- If you change the source or turn the power off, disc playback stops (without ejecting the disc). Next time you select the CD player as the source or turn the power on, disc play starts from where playback has been stopped previously.

## To stop play and eject the disc

Press .  
Playback stops and the control panel flips down.  
The disc automatically ejects from the loading slot.

## To change the display information

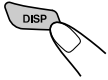

While playing back an MP3/WMA file, you can change the disc information shown on the display. Press DISP (display) repeatedly. Each time you press the button, the display changes to show the following:

- When “TAG DISP” is set to “TAG ON” (initial setting: see page 28)

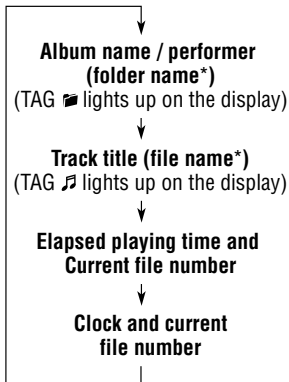

\* If ID3 tags are not recorded, folder name and file name appear. In this case, the TAG indicator will not light up on the display.

- When “TAG DISP” is set to “TAG OFF”

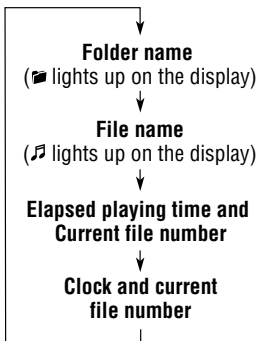

### Note:

- The display shows up to 8 characters at a time and scrolls if there are more than 8 characters. See also “To select the scroll mode—SCROLL” on page 28.
- When folder or file name is shown, current folder number or the **Tr** indicator and current file number also appear on the right side of the display.

## Locating a file or particular portion on a disc

### To fast-forward or reverse the file

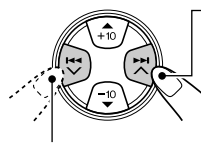

Press and hold **>>> ^** while playing a disc, to fast-forward the file.

Press and hold **◀◀◀ v** while playing a disc, to reverse the file.

### Note:

During this operation, you can only hear intermittent sounds. (The elapsed playing time also changes intermittently on the display.)

### To skip to the next or previous files

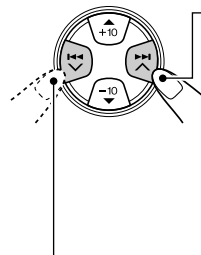

Press **>>> ^** briefly while playing, to skip ahead to the beginning of the next file. Each time you press the button consecutively, the beginning of the next files is located and played back.

Press **◀◀◀ v** briefly, while playing, to skip back to the beginning of the current file. Each time you press the button consecutively, the beginning of the previous files is located and played back.

## To go to a particular file quickly within the current folder (+10 and -10 buttons)

- 1 Press M MODE to enter the functions mode while playing a disc.



- 2 Press +10 or -10.

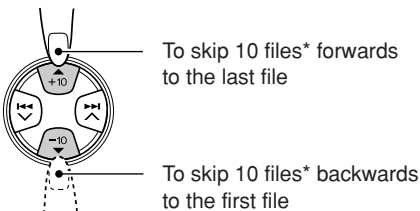

- \* The first time you press +10 or -10 button, the file skips to the nearest higher or lower file with a file number of multiple ten (ex. 10th, 20th, 30th).

Then, each time you press the button, you can skip 10 files (see "How to use the +10 and -10 buttons" below).

- After the last file, the first file will be selected, and vice versa.

### How to use the +10 and -10 buttons

- Ex. 1: To select file number 32 while playing file number 6

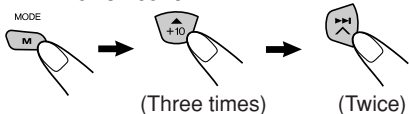

File 6 → 10 → 20 → 30 → 31 → 32

- Ex. 2: To select file number 8 while playing file number 36



File 36 → 30 → 20 → 10 → 9 → 8

## To go to a particular folder directly

### IMPORTANT:

To directly select the folders using the number button(s), it is required that folders are assigned 2 digit numbers at the beginning of their folder names. (This can only be done during the recording of CD-Rs or CD-RWs.)

Ex.: If folder name is "01 ABC"

→ Press 1 to go to Folder 01 ABC.

If folder name is "1 ABC," pressing 1 does not work.

If folder name is "12 ABC"

→ Press and hold 6 (12) to go to Folder 12 ABC.

Press the number button corresponding to the folder number to start playing the first file in the selected folder.

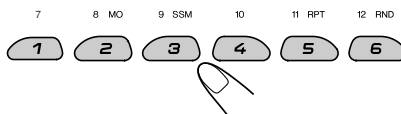

- To select a folder number from 01 – 06: Press 1 (7) – 6 (12) briefly.
- To select a folder number from 07 – 12: Press and hold 1 (7) – 6 (12) for more than one second.

### Notes:

- If  indicator flashes on the display after you have selected a folder, it means that the folder does not contain any MP3/WMA files.
- You cannot directly select a folder with a number greater than 12.

**To select a particular file in a folder, press**

▶▶| ▲ or |◀◀ ▼ after selecting the folder.

## To skip to the next or previous folder

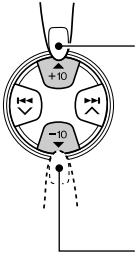

Press ▲ (up) while playing a disc to skip to the next folder.  
Each time you press the button consecutively, the next folder is located (and the first file in the folder starts playing, if recorded).

Press ▼ (down) while playing a disc to skip back to the previous folder.  
Each time you press the button consecutively, the previous folder is located (and the first file in the folder starts playing, if recorded).

**Note:**

*If the folder does not contain any MP3/WMA files, it is skipped.*

## Selecting playback modes

### To play back files at random (Folder Random/Disc Random Play)

You can play back all files of the current folder or all files on the disc at random.



**1** Press M MODE to enter the functions mode while playing a disc.

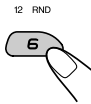

**2** Press RND (random), while “MODE” is still flashing on the display, so that “FLDR RND” or “DISC RND” appears on the display.

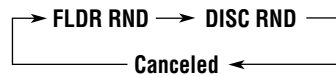

Each time you press the button, the random play mode changes as follows:

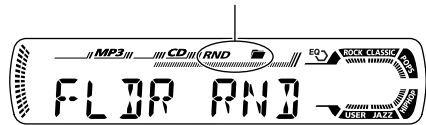

RND and  (folder) indicators



Ex.: When you select “FLDR RND” while listening to an MP3 file

Mode	Active indicator	Plays at random
FLDR RND	RND and  indicators light up.	All files of the current folder, then files of the next folder and so on.
DISC RND	RND and  indicators light up.	All files on the disc.

## To play back files repeatedly (Track Repeat/Folder Repeat Play)

You can play back the current file or all the files in the current folder repeatedly.

MODE



- 1 Press M MODE to enter the functions mode while playing a disc.

RPT



- 2 Press RPT (repeat), while "MODE" is still flashing on the display, so that "TRK RPT" or "FLDR RPT" appears on the display. Each time you press the button, the repeat play mode changes as follows:

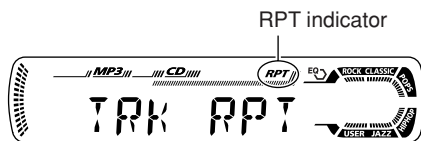

Ex.: When you select "TRK RPT" while listening to an MP3 file

Mode	Active indicator	Plays repeatedly
TRK RPT	RPT indicator lights up.	The current (or specified) file.
FLDR RPT	RPT and  indicators light up.	All files of the current (or specified) folder.



## Selecting preset sound modes (C-EQ: custom equalizer)

You can select a preset sound mode (C-EQ: custom equalizer) suitable to the music genre.

Select the sound mode you want.



Each time you press the button, the sound modes change as follows:

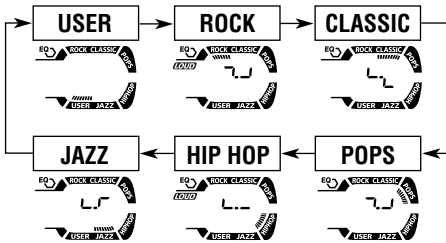

Indication pattern changes for each sound mode except for "USER"



Ex.: When you select "ROCK"

Indication	For:	Preset values		
		BAS	TRE	LOUD
USER	(Flat sound)	00	00	OFF
ROCK	Rock or disco music	+03	+01	ON
CLASSIC	Classical music	+01	-02	OFF
POPS	Light music	+04	+01	OFF
HIP HOP	Funk or rap music	+02	00	ON
JAZZ	Jazz music	+02	+03	OFF

**Note:**

You can adjust each sound mode to your preference. Once you make an adjustment, it is automatically stored for the currently selected sound mode. See "Adjusting the sound" on page 24.



## Adjusting the sound

You can adjust the sound characteristics to your preference.

### 1 Select the item you want to adjust.



Each time you press the button, the adjustable items change as follows:

For KD-AR600:

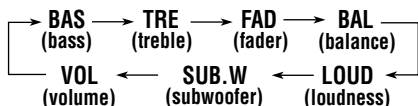

For KD-SC500:

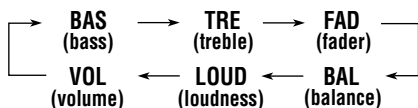

Indication	To do:	Range
BAS* <sup>1</sup>	Adjust the bass.	-06 (min.)   +06 (max.)
TRE* <sup>1</sup>	Adjust the treble.	-06 (min.)   +06 (max.)
FAD* <sup>2</sup>	Adjust the front and rear speaker balance.	R06 (Rear only)   F06 (Front only)
BAL	Adjust the left and right speaker balance.	L06 (Left only)   R06 (Right only)
LOUD* <sup>1</sup>	Boost low and high frequencies to produce a well-balanced sound at low volume level.	LOUD ON   LOUD OFF
SUB.W* <sup>3</sup> (only for KD-AR600)	Adjust the subwoofer output level.	00 (min.)   08 (max.)
VOL* <sup>4</sup>	Adjust the volume.	00 (min.)   30 or 50 (max.)* <sup>5</sup>

\*<sup>1</sup> When you adjust the bass, treble, or loudness, the adjustment you have made is stored for the currently selected sound mode (C-EQ) including "USER."

\*<sup>2</sup> If you are using a two-speaker system, set the fader level to "00."

\*<sup>3</sup> Only for KD-AR600:

This takes effect only when a subwoofer is connected.

\*<sup>4</sup> Normally the control dial work as the volume control. So you do not have to select "VOL" to adjust the volume level.

\*<sup>5</sup> Depending on the amplifier gain control. (See page 28 for details.)

### 2 Adjust the setting.



To increase the level or turn on the loudness

To decrease the level or turn off the loudness

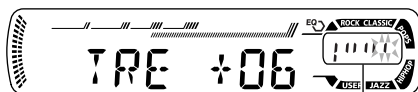

Indication pattern changes as you adjust the bass or treble.

Ex. 1: When you adjust "TRE" (treble)



Ex. 2: When you turn on the loudness

### 3 Repeat steps 1 and 2 to adjust the other items.

To reset each sound mode to the factory settings, repeat the same procedure and reassign the preset values listed in the table on page 23.





## Changing the general settings (PSM)

You can change the items listed on the next page by using the PSM (Preferred Setting Mode) control.

### Basic Procedure

- 1** Press and hold SEL (select) for more than 2 seconds so that one of the PSM items appears on the display. (See page 26.)



- 2** Select the PSM item you want to adjust. (See page 26.)

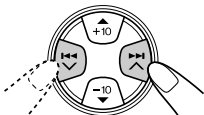

- 3** Adjust the PSM item selected.



- 4** Repeat steps 2 and 3 to adjust the other PSM items if necessary.

- 5** Finish the setting.





## Preferred Setting Mode (PSM) items

• For detailed operations of each PSM items, refer to the pages listed in the table.

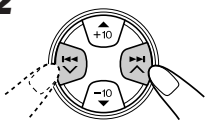
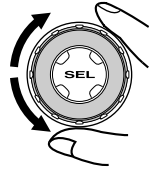
		 <b>1</b> Hold...		 <b>2</b> Select...		 <b>3</b> Set... Counter-clockwise      Clockwise		Factory-preset settings	See page
<b>DEMO</b>	Display demonstration	DEMO OFF	DEMO ON	DEMO ON	8				
<b>CLOCK H</b>	Hour adjustment	Back	Advance	1 (1:00)	9				
<b>CLOCK M</b>	Minute adjustment	Back	Advance	00 (1:00)	9				
<b>COLOR</b>	Color adjustment	(See page 27)		ALL DEMO	27				
<b>LEVEL</b>	Level display	OFF	ON	ON	27				
<b>DIMMER</b>	Dimmer mode	AUTO ↙	↔ ON	OFF ↘	AUTO 27				
<b>BEEP</b> (only for KD-AR600)	Key-touch tone	OFF	ON	ON	27				
<b>SCROLL</b>	Scroll mode	ONCE ↙	↔ OFF	AUTO ↘	ONCE 28				
<b>EXT IN*</b> (only for KD-AR600)	External component	CHANGER ↙	↔ SIRIUS	LINE IN ↘	CHANGER 28				
<b>TAG DISP</b>	Tag display	TAG OFF	TAG ON	TAG ON	28				
<b>AMP GAIN</b>	Amplifier gain control	LOW PWR	HIGH PWR	HIGH PWR	28				

• Press SEL (select) to finish the setting.

\* Displayed only when one of the following sources is selected—FM, AM, and CD.



## To select the display color—COLOR

You can select the color of the display according to your preference.

When shipped from the factory, “ALL DEMO” is selected.

The selectable colors are as follows:

ALL DEMO ⇄ SOURCE ⇄ BLUE ⇄  
OCEAN ⇄ PURPLE ⇄ PINK ⇄ ROSE ⇄  
RED ⇄ (back to the beginning)

- ALL DEMO: The display color changes every 6 seconds (rose → pink → ocean → red → purple → blue → back to the beginning).
- SOURCE: The display color is fixed to red while listening to FM or AM, blue while listening to CD, and purple while listening to external component (only for KD-AR600).

## To select the level meter—LEVEL

You can activate or deactivate the level meter according to your preference.

When shipped from the factory, level meter is activated.

- ON: Shows the audio level indicator.
- OFF: Cancels the audio level indicator; sound mode indicator is shown.

## To select the dimmer mode—DIMMER

When you turn on the car head lights, the display automatically dims (Auto Dimmer).

When shipped from the factory, Auto Dimmer mode is activated.

- AUTO: Activates Auto Dimmer.
- OFF: Cancels Auto Dimmer.
- ON: Always dims the display.

### Note:

*Auto Dimmer equipped with this unit may not work correctly on some vehicles, particularly on those having a control dial for dimming.*

*In this case, set the dimmer mode to “ON” or “OFF.”*

## To turn on/off the key-touch tone—BEEP (only for KD-AR600)

You can deactivate the key-touch tone if you do not want it to beep each time you press a button. When shipped from the factory, the key-touch tone is activated.

- ON: Activates the key-touch tone.
- OFF: Deactivates the key-touch tone.



## To select the scroll mode—SCROLL

You can select the scroll mode for the disc information (when the entire text cannot be shown all at once).

When shipped from the factory, scroll mode is set to “ONCE.”

- ONCE: Scrolls only once.
- AUTO: Repeats the scroll (5-second intervals in between).
- OFF: Cancels Auto Scroll.

### Note:

Even if the scroll mode is set to “OFF,” you can scroll the display by pressing DISP (display) for more than one second.

## To select the external component to use—EXT IN (only for KD-AR600)

You can connect the external component to the CD changer jack on the rear using an adapter specially designed for the external component. To use the external component as the playback source through this unit, you need to select which component—CD changer or external component—to use.

When shipped from the factory, CD changer is selected as the external component.

- CHANGER: To use the CD changer.
- LINE IN: To use the external component other than CD changer.
- SIRIUS: To use the JVC SIRIUS Radio.

### Notes:

- For connecting the Line Input Adapter KS-U57 and the external component, refer to the Installation/Connection Manual (separate volume).
- For connecting the JVC SIRIUS Radio, refer to the SIRIUS Radio Setup Manual (separate volume).

## To turn the tag display on or off—TAG DISP

An MP3/WMA file can contain file information called “ID3 Tag” where its album name, performer, track title, etc. are recorded. There are two versions—ID3v1 (ID3 Tag version 1) and ID3v2 (ID3 Tag version 2). If both ID3v1 and ID3v2 are recorded on a disc, ID3v2 information will be shown.

When shipped from the factory, “TAG ON” is selected.

- TAG ON: Turns on the ID3 tag display while playing MP3/WMA files.
  - If an MP3/WMA file does not have ID3 tags, folder name and file name appear.

### Note:

If you change the setting from “TAG OFF” to “TAG ON” while playing an MP3/WMA file, the tag display will be activated when the next file starts playing. (only for KD-AR600)

- TAG OFF: Turns off the ID3 tag display while playing MP3/WMA files. (Only the folder name and file name can be shown.)

## To select the amplifier gain control—AMP GAIN

You can change the maximum volume level of this unit. When the maximum power of the speakers is less than 50 W, select “LOW PWR” to prevent them from being damaged. When shipped from the factory, “HIGH PWR” is selected.

- LOW PWR: You can adjust the volume level from “VOL 00” to “VOL 30.”

### Note:

If you change the initial setting from “HIGH PWR” to “LOW PWR” while listening at a volume level more than 30, the unit automatically changes the volume level to “VOL 30.”

- HIGH PWR: You can adjust the volume level from “VOL 00” to “VOL 50.”



# Assigning names to the sources

You can assign names to station frequencies and CDs (both in this unit and in the CD changer only for KD-AR600).

After assigning a name, it will appear on the display when you select the source.

Sources	Maximum number of characters
Station frequencies	Up to 8 characters (up to 30 station frequencies including both FM and AM)
CDs*	Up to 32 characters (up to 40 discs)

\* You cannot assign a name to a CD Text or an MP3/WMA disc.

## 1 Select a source you want to assign a name to.

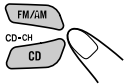

(For KD-AR600)

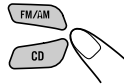

(For KD-SC500)

When you select a source, the power automatically comes on.

## 2 While pressing DISP (display), press and hold SEL (select) for more than 2 seconds.

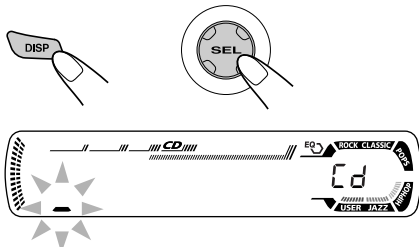

Ex.: When you select CD as the source

## 3 Select a character.

- See below for available characters.



## 4 Move the cursor to the next (or previous) character position.

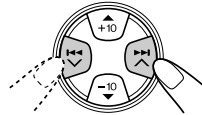

## 5 Repeat steps 3 and 4 until you finish entering the name.

## 6 Finish the procedure while the last selected character is flashing.



### To erase the input characters

To erase all the characters at a time, press and hold DISP (display) for more than 1 second as described in the procedure above.

### Available characters

A	B	C	D	E	F	G	H	I	J
K	L	M	N	O	P	Q	R	S	T
U	V	W	X	Y	Z	0	1	2	3
4	5	6	7	8	9	-	/	<	>
space									

### Notes:

- When you try to assign a name to the 41st disc, "NAME FULL" appears on the display. (In this case, delete unwanted names before assignment.)
- When the CD changer is connected, you can assign names to CDs in the CD changer. These names can also be shown on the display if you insert the CDs in this unit (only for KD-AR600).



## Changing the standard plate

You can change the standard plate with another plate supplied with your unit.

You can also download them by visiting <<http://www.jvc.co.jp/jvccar>>.

- When changing the plate, be careful not to leave your fingerprints on the plate or cover.

### 1 Loosen the screws with the supplied hex screwdriver.

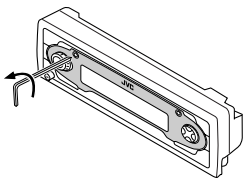

### 2 Remove the plate cover and the standard plate.

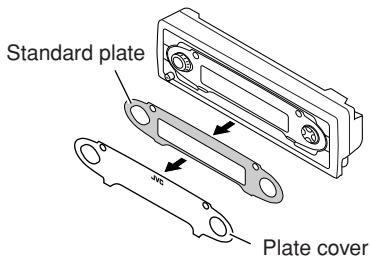

### 3 Replace with another plate (a standard, cutout, or downloaded plate) of your preference.

- When attaching a standard plate

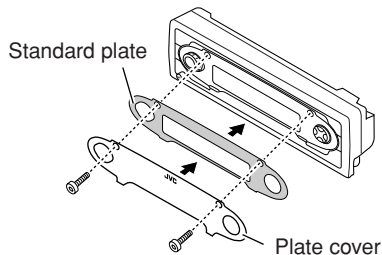

- When attaching a cutout or downloaded plate

Add the transparent plate (supplied) between the cutout or downloaded plate and the plate cover in order to attach the plate cover in place.

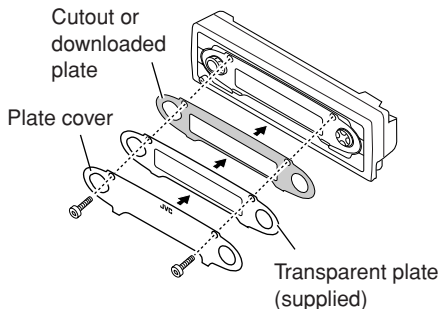

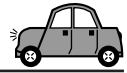

### When attaching the plate cover

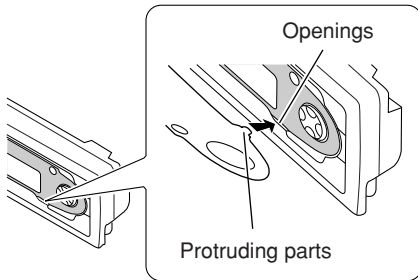

Ensure the two protruding parts at the bottom of the plate cover are inserted into the two openings on the control panel, as illustrated.

#### Notes:

- Be sure to keep the hex screwdriver for future use.
- Two spare screws for the plate cover attachment are provided with the unit. See the *Installation/Connection Manual* (separate volume).
- When you attach the plate cover, do not tighten the screws too hard; otherwise, the plate cover might be cracked.

### How to use the cutout plates

1 Unfold the supplied cutout plates.

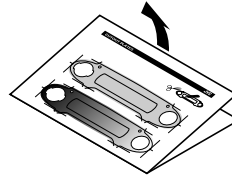

2 Cut the plates out using a scissors.

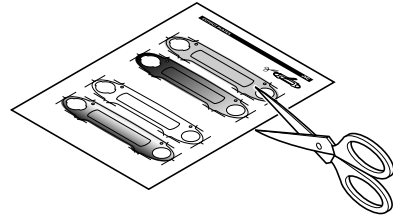

3 Trim out the window and two knobs using a knife on a rubber mat.

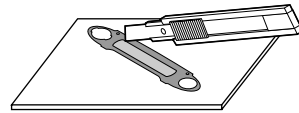



## Detaching the control panel

You can detach the control panel when leaving the car.

When detaching or attaching the control panel, be careful not to damage the connectors on the back of the control panel and on the panel holder.

### Detaching the control panel

Before detaching the control panel, be sure to turn off the power.

- 1** Unlock the control panel.

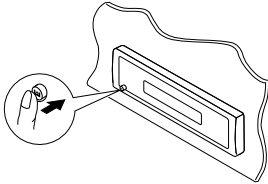

- 2** Pull the control panel out of the unit.

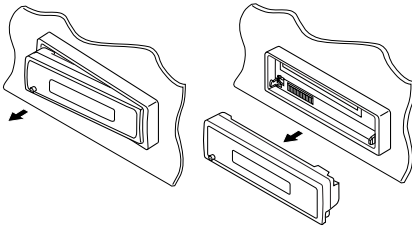

- 3** Put the detached control panel into the provided case.

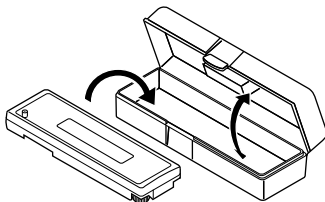

## Attaching the control panel

- 1** Insert the right side of the control panel into the groove on the panel holder.

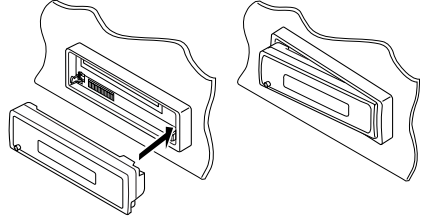

- 2** Press the left side of the control panel to fix it to the panel holder.

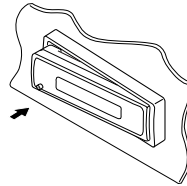

**Note on cleaning the connectors:**

*If you frequently detach the control panel, the connectors will deteriorate.*

*To minimize this possibility, periodically wipe the connectors with a cotton swab or cloth moistened with alcohol, being careful not to damage the connectors.*

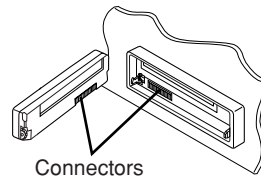



# CD CHANGER OPERATIONS (Only for KD-AR600)

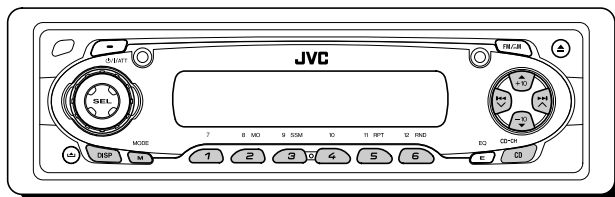
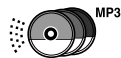

We recommend that you use the JVC MP3-compatible CD changer with your unit.

By using this CD changer, you can play back your original CD-Rs (Recordable) and CD-RWs (Rewritable) recorded either in audio CD format or in MP3 format.

- You can also connect other CH-X series CD changers (except CH-X99 and CH-X100). However, they are not compatible with MP3 discs, so you cannot play back MP3 discs.
- You cannot use the KD-MK series CD changers with this unit.

Before operating your CD changer:

- Refer also to the Instructions supplied with your CD changer.
- If no discs are in the magazine of the CD changer or the discs are inserted upside down, "NO DISC" will appear on the display. If this happens, remove the magazine and set the discs correctly.
- If no magazine is loaded in the CD changer, "NO MAG" appears on the display. If this happens, insert the magazine in the CD changer.
- If "RESET 1" – "RESET 8" appears on the display, something is wrong with the connection between this unit and the CD changer. If this happens, check the connection and make sure the cords are connected firmly. Then, press the reset button of the CD changer.

**Note:**

You cannot control and play any WMA disc on the CD changer.

## Playing discs

### Select the CD changer (CD-CH).



\* If you have changed "EXT IN" setting to "LINE IN" (see page 28), you cannot select the CD changer.

- **When the current disc is an MP3 disc:** Playback starts from the first folder of the current disc once file check is completed.

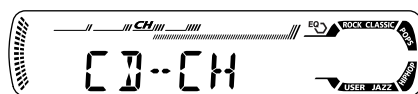

Selected disc number ↓



MP3 indicator ↓

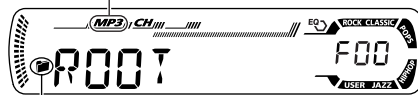

■ (folder) indicator

**Note:**

Folder name appears on the display instead of "ROOT," if an MP3 disc contains a folder.

- **When the current disc is a CD:**  
Playback starts from the first track of the current disc.

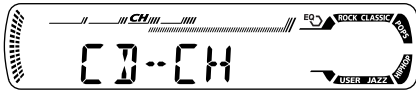

Selected disc number ↓

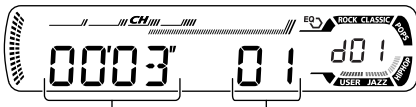
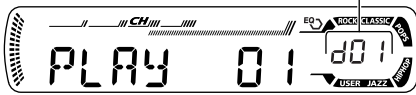

Elapsed playing time      Current track number

**Notes:**

- When you press CD CD-CH, the power automatically comes on. You do not have to press **POWER** to turn on the power.
- If you change the source, CD changer play also stops. Next time you select the CD changer as the source, CD changer play starts from where playback has been stopped previously.
- When you start playing back a CD Text or MP3 disc, disc information will automatically appear on the display. (See pages 16 and 19.)

**To go to a particular disc directly**

Press the number button corresponding to the disc number to start its playback (while the CD changer is playing).

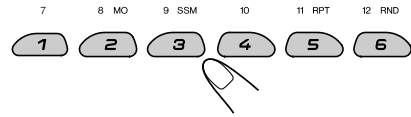

- To select a disc number from 1 – 6:  
Press 1 (7) – 6 (12) briefly.
- To select a disc number from 7 – 12:  
Press and hold 1 (7) – 6 (12) for more than one second.

**To fast-forward or reverse the track/file**

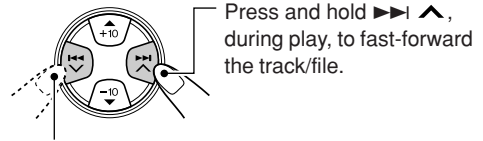

Press and hold **FF** **▲**, during play, to fast-forward the track/file.

Press and hold **REW** **▼**, during play, to reverse the track/file.

**Note:**

During this operation, you can only hear intermittent sounds. (The elapsed playing time also changes intermittently on the display.)

**To go to the next or previous tracks/files**

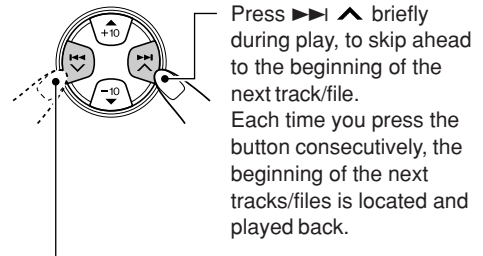

Press **▶▶** **▲** briefly during play, to skip ahead to the beginning of the next track/file. Each time you press the button consecutively, the beginning of the next tracks/files is located and played back.

Press **◀◀** **▼** briefly during play, to skip back to the beginning of the current track/file. Each time you press the button consecutively, the beginning of the previous tracks/files is located and played back.

This operation is only possible when using JVC MP3-compatible CD changer (CH-X1500).

### To go to a track/file quickly (+10 and -10 buttons)

- 1 Press M MODE to enter the functions mode while playing a disc.



- 2 Press +10 or -10.

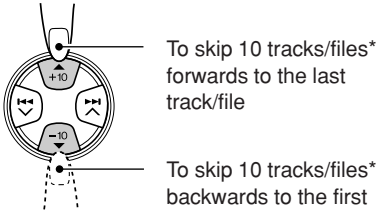

\* The first time you press +10 or -10 button, the track/file skips to the nearest higher or lower track/file with a track/file number of multiple ten (ex. 10th, 20th, 30th).

Then, each time you press the button, you can skip 10 tracks/files (see "How to use the +10 and -10 buttons" below).

- After the last track/file, the first track/file will be selected, and vice versa.

**Note:**

If the current playing disc is an MP3 disc, files are skipped within the same folder.

### How to use the +10 and -10 buttons

- Ex. 1: To select track/file number 32 while playing track/file number 6

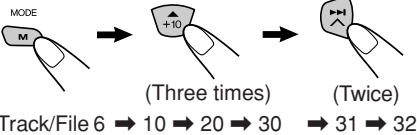

- Ex. 2: To select track/file number 8 while playing track/file number 36

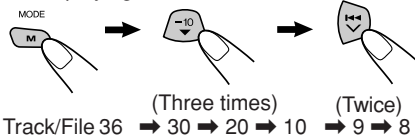

### To skip to the next or previous folder (only for MP3 discs)

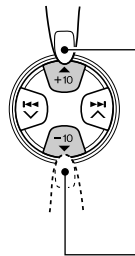

Press ▲ (up) while playing an MP3 disc, to go to the next folder.

Each time you press the button consecutively, the next folder is located, and the first file in the folder starts playback.

Press ▼ (down) while playing an MP3 disc, to go to the previous folder.

Each time you press the button consecutively, the previous folder is located, and the first file in the folder starts playback.

### To show the disc information for CD Text and MP3 discs

This is possible only when connecting a JVC CD changer equipped with CD Text and/or MP3 disc information reading capability.

### Select text display mode while playing a CD Text or an MP3 disc.



- For details, see page 16 about CD Text disc information and page 19 about MP3 disc information.

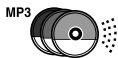

# Selecting the playback modes

## To play back tracks/files at random (Folder Random/Disc Random/Magazine Random Play)

- 1 Press M MODE to enter the functions mode during play.
- 2 Press RND (random), while "MODE" is still flashing on the display. Each time you press the button, the random play mode changes as follows:

For MP3 discs:

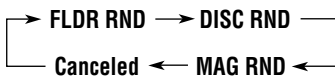

For CDs:

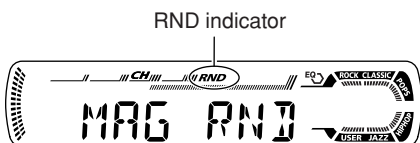
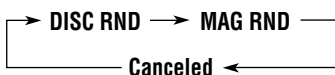

Ex.: When you select "MAG RND"

**Note:**

MP3 indicator also lights up if the current playing disc is an MP3 disc.

Mode	Active indicator	Plays at random
FLDR RND*	RND and  indicators light up.	All files of the current folder, then files of the next folder and so on.
DISC RND	RND and  indicators light up.	All tracks/files of the current (or specified) disc.
MAG RND	RND indicator lights up.	All tracks/files of the inserted discs.

\* "FLDR RND" is only applicable for MP3 disc.

## To play back tracks/files repeatedly (Track Repeat/Folder Repeat/Disc Repeat Play)

- 1 Press M MODE to enter the functions mode during play.
- 2 Press RPT (repeat), while "MODE" is still flashing on the display. Each time you press the button, the repeat play mode changes as follows:

For MP3 discs:

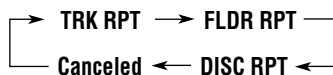

For CDs:



RPT and (disc) indicators

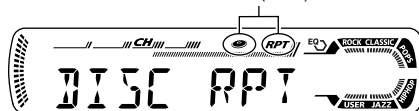

Ex.: When you select "DISC RPT"

**Note:**

MP3 indicator also lights up if the current playing disc is an MP3 disc.

Mode	Active indicator	Plays repeatedly
TRK RPT	RPT indicator lights up.	The current (or specified) track/file.
FLDR RPT*	RPT and  indicators light up.	All files of the current (or specified) folder of the current disc.
DISC RPT	RPT and  indicators light up.	All tracks/files of the current (or specified) disc.

\* "FLDR RPT" is only applicable for MP3 disc.

# EXTERNAL COMPONENT OPERATIONS



(Only for KD-AR600)

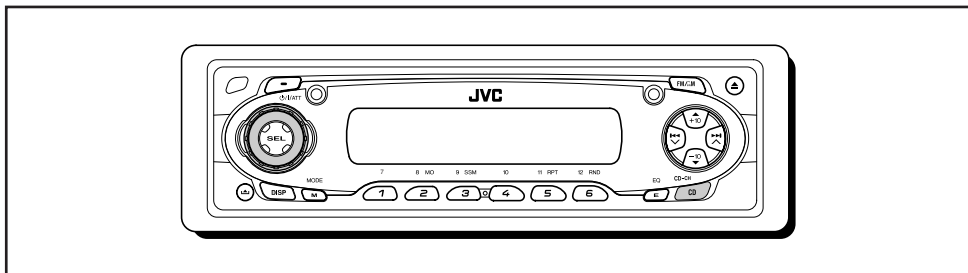

## Playing an external component

You can connect the external component to the CD changer jack on the rear using the Line Input Adapter KS-U57 (not supplied).

### Preparations:

- For connecting the Line Input Adapter KS-U57 and the external component, refer to the Installation/Connection Manual (separate volume).
- Before operating the external component using the following procedure, select the external input correctly. See “To select the external component to use—EXT IN” on page 28.

### 1 Select the external component (LINE IN).

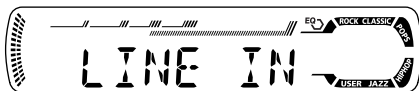

### 2 Turn on the connected component and start playing the source.

### 3 Adjust the volume.



### 4 Adjust the sound characteristics you want. (See pages 23 and 24.)

To use the JVC SIRIUS Radio, refer to the SIRIUS Radio Setup Manual (separate volume).

- If “LINE IN”\* does not appear on the display, see page 28 and select the external input (“LINE IN”).

\* Displayed only when one of the following sources is selected—FM, AM, and CD.

### Note on One-Touch Operation:

When you press CD CD-CH, the power automatically comes on. You do not have to press /I/ATT to turn on the power.



# TROUBLESHOOTING

ENGLISH

What appears to be trouble is not always serious. Check the following points before calling a service center.

	Symptoms	Causes	Remedies
General	<ul style="list-style-type: none"> <li>Sound cannot be heard from the speakers.</li> </ul>	The volume level is set to the minimum level.	Adjust it to the optimum level.
		Connections are incorrect.	Check the cords and connections.
	<ul style="list-style-type: none"> <li>This unit does not work at all.</li> </ul>	The built-in microcomputer may have functioned incorrectly due to noise, etc.	Press the reset button on the panel holder after detaching the control panel. (The clock setting and preset stations stored in memory are erased.) (See page 2.)
FM/AM	<ul style="list-style-type: none"> <li>SSM (Strong-station Sequential Memory) automatic preset does not work.</li> </ul>	Signals are too weak.	Store stations manually.
	<ul style="list-style-type: none"> <li>Static noise while listening to the radio.</li> </ul>	The antenna is not connected firmly.	Connect the antenna firmly.
Disc Playback	<ul style="list-style-type: none"> <li>Disc cannot be played back.</li> </ul>	Disc is inserted upside down.	Insert the disc correctly.
	<ul style="list-style-type: none"> <li>CD-R/CD-RW cannot be played back.</li> <li>Tracks on the CD-R/CD-RW cannot be skipped.</li> </ul>	CD-R/CD-RW is not finalized.	<ul style="list-style-type: none"> <li>Insert a finalized CD-R/CD-RW.</li> <li>Finalize the CD-R/CD-RW with the component which you used for recording.</li> </ul>
		Disc cannot be ejected.	Disc is locked.
	<ul style="list-style-type: none"> <li>Disc sound is sometimes interrupted.</li> </ul>	You are driving on rough roads.	Stop playback while driving on rough roads.
		Disc is scratched.	Change the disc.
		Connections are incorrect.	Check the cords and connections.
	<ul style="list-style-type: none"> <li>"NO DISC" appears on the display.</li> </ul>	No disc in the loading slot.	Insert a disc into the loading slot.
Disc is inserted incorrectly.		Insert the disc correctly.	



Symptoms	Causes	Remedies
<ul style="list-style-type: none"> <li>Disc cannot be played back.</li> </ul>	No MP3/WMA files are recorded on the disc.	Change the disc.
	MP3/WMA files do not have the extension code—<.mp3> or <.wma> in their file names.	Add the extension code—<.mp3> or <.wma> to their file names.
	MP3/WMA files are not recorded in the format compliant with ISO 9660 Level 1, Level 2, or Joliet.	Change the disc. (Record MP3/WMA files using a compliant application.)
<ul style="list-style-type: none"> <li>Noise is generated.</li> </ul>	The file played back is not an MP3/WMA file (although it has the extension code—<.mp3> or <.wma>).	Skip to another file or change the disc. (Do not add the extension code—<.mp3> or <.wma> to non-MP3 or non-WMA files.)
<ul style="list-style-type: none"> <li>A longer readout time is required (“CHECK” keeps flashing on the display).</li> </ul>	Readout time varies due to the complexity of the folder/file configuration.	Do not use too many hierarchies and folders.
<ul style="list-style-type: none"> <li>Files cannot be played back as you have intended them to play.</li> </ul>	Playback order is determined when the files are recorded.	_____
<ul style="list-style-type: none"> <li>Elapsed playing time is not correct.</li> </ul>	This sometimes occurs during play. This is caused by how the files are recorded on the disc.	_____
<ul style="list-style-type: none"> <li> indicator flashes on the display.</li> </ul>	The current folder does not contain any MP3/WMA file.	Select another folder.
<ul style="list-style-type: none"> <li>“NO FILES” appears on the display.</li> </ul>	The current disc does not contain any MP3/WMA file.	Insert a disc that contains MP3/WMA files.
<ul style="list-style-type: none"> <li>Correct characters are not displayed (e.g. album name).</li> </ul>	This unit can only display alphabets (capital: A–Z), numbers, and a limited number of symbols.	_____

MP3/WMA Playback



## (only for KD-AR600)

	Symptoms	Causes	Remedies
CD Changer	• “NO DISC” appears on the display.	No disc is in the magazine. Discs are inserted upside down.	Insert discs into the magazine. Insert discs correctly.
	• “NO MAG” appears on the display.	No magazine is loaded in the CD changer.	Insert the magazine.
	• “RESET 8” appears on the display.	This unit is not connected to the CD changer correctly.	Connect this unit and the CD changer correctly and press the reset button of the CD changer.
	• “RESET 1” – “RESET 7” appears on the display.	_____	Press the reset button of the CD changer.
	• The CD changer does not work at all.	The built-in microcomputer may function incorrectly due to noise, etc.	Press the reset button on the panel holder after detaching the control panel. (The clock setting and preset stations stored in memory are erased.) (See page 2.)

**About mistracking:**

*Mistracking may result from driving on extremely rough roads. This does not damage the unit and the disc, but will be annoying.*

*We recommend that you stop disc play while driving on such rough roads.*



## Handling discs

This unit has been designed to reproduce CDs, CD-Rs (Recordable), CD-RWs (Rewritable), and CD Texts.

- **This unit is also compatible with MP3 and WMA discs.**

### How to handle discs

**When removing a disc from its case**, press down the center holder of the case and lift the disc out, holding it by the edges.

- Always hold the disc by the edges. Do not touch its recording surface.

Center holder



**When storing a disc into its case**, gently insert the disc around the center holder (with the printed surface facing up).

- Make sure to store discs into the cases after use.

### To keep discs clean

A dirty disc may not be played correctly.

If a disc does become dirty, wipe it with a soft cloth in a straight line from center to edge.



### To play new discs

New discs may have some rough spots around the inner and outer edges. If such a disc is used, this unit may reject the disc.

To remove these rough spots, rub the edges with a pencil or ball-point pen, etc.



### Moisture condensation

Moisture may condense on the lens inside the CD player in the following cases:

- After starting the heater in the car.
- If it becomes very humid inside the car.

Should this occur, the CD player may malfunction. In this case, eject the disc and leave the unit turned on for a few hours until the moisture evaporates.

### When playing a CD-R or CD-RW

Before playing back CD-Rs or CD-RWs, read their instructions or cautions carefully.

- Use only "finalized" CD-Rs or CD-RWs.
- Some CD-Rs or CD-RWs may not be played back on this unit because of their disc characteristics, and for the following reasons:
  - Discs are dirty or scratched.
  - Moisture condensation on the lens inside the unit.
  - The pickup lens inside the unit is dirty.
- CD-RWs may require a longer readout time since the reflectance of CD-RWs is lower than that of regular CDs.
- CD-Rs or CD-RWs are susceptible to high temperatures or high humidity, so do not leave them inside your car.
- Do not use following CD-Rs or CD-RWs:
  - Discs with stickers, labels, or protective seal stuck to the surface.
  - Discs on which labels can be directly printed by an ink jet printer.

Using these discs under high temperatures or high humidity may cause malfunctions or damage to discs. For example,

- Stickers or labels may shrink and warp a disc.
- Stickers or labels may be peeled off so discs cannot be ejected.
- Print on discs may get sticky.

Read instructions or cautions about labels and printable discs carefully.

#### CAUTIONS:

- Do not insert 8 cm (3-3/16") discs (single CDs) into the loading slot. (Such discs cannot be ejected.)
- Do not insert any disc of unusual shape—like a heart or flower; otherwise, it will cause a malfunction.
- Do not expose discs to direct sunlight or any heat source or place them in a place subject to high temperature and humidity. Do not leave them in a car.
- Do not use any solvent (for example, conventional record cleaner, spray, thinner, benzene, etc.) to clean discs.

Warped disc



Sticker



Sticker residue

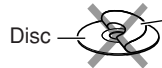

Disc  
Stick-on label

# SPECIFICATIONS

## AUDIO AMPLIFIER SECTION

Maximum Power Output:

Front: 50 W per channel

Rear: 50 W per channel

Continuous Power Output (RMS):

Front: 19 W per channel into 4  $\Omega$ , 40 Hz to 20 000 Hz at no more than 0.8% total harmonic distortion.

Rear: 19 W per channel into 4  $\Omega$ , 40 Hz to 20 000 Hz at no more than 0.8% total harmonic distortion.

Load Impedance: 4  $\Omega$  (4  $\Omega$  to 8  $\Omega$  allowance)

Tone Control Range:

Bass:  $\pm 10$  dB at 100 Hz

Treble:  $\pm 10$  dB at 10 kHz

Frequency Response: 40 Hz to 20 000 Hz

Signal-to-Noise Ratio: 70 dB

Line-Out Level/Impedance:

KD-AR600: 4.0 V/20 k $\Omega$  load (full scale)

KD-SC500: 2.5 V/20 k $\Omega$  load (full scale)

Output Impedance: 1 k $\Omega$

Only for KD-AR600:

Subwoofer-Out Level/Impedance:

2.0 V/20 k $\Omega$  load (full scale)

Cut off frequency: 120 Hz (fixed)

## TUNER SECTION

Frequency Range:

FM: 87.5 MHz to 107.9 MHz

AM: 530 kHz to 1 710 kHz

### [FM Tuner]

Usable Sensitivity: 11.3 dBf (1.0  $\mu$ V/75  $\Omega$ )

50 dB Quieting Sensitivity: 16.3 dBf (1.8  $\mu$ V/75  $\Omega$ )

Alternate Channel Selectivity (400 kHz): 65 dB

Frequency Response: 40 Hz to 15 000 Hz

Stereo Separation: 35 dB

Capture Ratio: 1.5 dB

### [AM Tuner]

Sensitivity: 20  $\mu$ V

Selectivity: 35 dB

## CD PLAYER SECTION

Type: Compact disc player

Signal Detection System: Non-contact optical pickup (semiconductor laser)

Number of channels: 2 channels (stereo)

Frequency Response: 5 Hz to 20 000 Hz

Dynamic Range: 96 dB

Signal-to-Noise Ratio: 98 dB

Wow and Flutter: Less than measurable limit

MP3 decoding format:

MPEG 1/2 Audio Layer 3.

Max. Bit Rate: 320 Kbps

WMA (Windows Media<sup>®</sup> Audio) decoding format:

Max. Bit Rate: 192 Kbps

## GENERAL

Power Requirement:

Operating Voltage:

DC 14.4 V (11 V to 16 V allowance)

Grounding System: Negative ground

Allowable Operating Temperature:

0°C to +40°C (32°F to 104°F)

Dimensions (W  $\times$  H  $\times$  D):

Installation Size (approx.):

182 mm  $\times$  52 mm  $\times$  150 mm

(7-3/16"  $\times$  2-1/16"  $\times$  5-15/16")

Panel Size (approx.):

188 mm  $\times$  58 mm  $\times$  12 mm

(7-7/16"  $\times$  2-5/16"  $\times$  1/2")

Mass (approx.):

1.4 kg (3.1 lbs) (excluding accessories)

*Design and specifications are subject to change without notice.*

If a kit is necessary for your car, consult your telephone folder for the nearest car audio speciality shop.



**JVC**

**MOBILE**  
ENTERTAINMENT

<http://www.jvcmobile.com>

*Visit us on-line for*

*Technical Support & Customer Satisfaction Survey.*

**US RESIDENTS ONLY**

**Having TROUBLE with operation?  
Please reset your unit**

**Refer to page of How to Reset  
Still having trouble??**

**USA ONLY**

**Call 1-800-252-5722**

<http://www.jvc.com>

**We can help you!**

**JVC**

VICTOR COMPANY OF JAPAN, LIMITED



EN, SP, FR

© 2003 VICTOR COMPANY OF JAPAN, LIMITED

1003KKSFLEJEIN

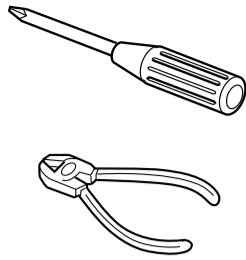

### ENGLISH

- This unit is designed to operate on 12 V DC, NEGATIVE ground electrical systems.

## INSTALLATION (IN-DASH MOUNTING)

- The following illustration shows a typical installation. However, you should make adjustments corresponding to your specific car. If you have any questions or require information regarding installation kits, consult your JVC car audio dealer or a company supplying kits.

- 1 Before mounting:** Press (Control Panel Release button) to detach the control panel if already attached.  
\* When shipped from the factory, the control panel is packed in the hard case.
- Remove the trim plate.
- Remove the sleeve after disengaging the sleeve locks.
  - Stand the unit.  
**Note:** When you stand the unit, be careful not to damage the fuse on the rear.
  - Insert the 2 handles between the unit and the sleeve, as illustrated, to disengage the sleeve locks.
  - Remove the sleeve.  
**Note:** Be sure to keep the handles for future use after installing the unit.
- Install the sleeve into the dashboard.  
\* After the sleeve is correctly installed in the dashboard, bend the appropriate tabs to hold the sleeve firmly in place, as illustrated.
- Fix the mounting bolt to the rear of the unit's body and place the rubber cushion over the end of the bolt.
- Do the required electrical connections.
- Slide the unit into the sleeve until it is locked.
- Attach the trim plate.  
**Note:** Ensure the recessed part is at the bottom. If not, the control panel will not open completely.
- Attach the control panel.

### ESPAÑOL

- Esta unidad está diseñada para funcionar con 12 V de CC, con sistemas eléctricos de masa NEGATIVA.

## INSTALACION (MONTAJE EN EL TABLERO DE INSTRUMENTOS)

- La siguiente ilustración muestra una instalación típica. Sin embargo usted deberá efectuar los ajustes correspondientes a su automóvil. Si tiene alguna pregunta o necesita información acerca de las herramientas para instalación, consulte con su concesionario de JVC de equipos de audio para automóviles o a una compañía que suministra tales herramientas.

- 1 Antes de instalar:** Pulse (botón de liberación del panel de control) para desenganchar el panel de control, si ya está fijado.  
\* El panel de control se expide de fábrica dentro del estuche duro.
- Retire la placa de guarnición.
- Retire la cubierta después de desenganchar los retenes de la cubierta.
  - Ponga la unidad vertical.  
**Nota:** Al poner la unidad vertical, tenga cuidado de no dañar el fusible provisto en la parte posterior.
  - Inserte las dos manijas entre la unidad y la cubierta tal como en la ilustración y desenganche los retenes de la cubierta.
  - Retire la cubierta.  
**Nota:** Después de instalar la unidad, asegúrese de guardar las manijas para uso futuro.
- Instale la cubierta en el tablero de instrumentos.  
\* Después de que la cubierta esté correctamente instalada en el tablero de instrumentos, doble las lengüetas correspondientes para sostener la cubierta firmemente en su lugar, tal como se muestra.
- Fije el perno de montaje en la parte trasera del cuerpo de la unidad y coloque el cojín de goma sobre el extremo del perno.
- Realice las conexiones eléctricas requeridas.
- Deslice la unidad dentro de la cubierta hasta que quede trabada.
- Coloque la placa de guarnición.  
**Nota:** Asegúrese de que la parte ahuecada quede en la parte inferior. De lo contrario, el panel de control no se podrá abrir por completo.
- Coloque el panel de control.

### FRANÇAIS

- Cet appareil est conçu pour fonctionner sur des sources de courant continu de 12 V à masse NEGATIVE.

## INSTALLATION (MONTAGE DANS LE TABLEAU DE BORD)

- L'illustration suivante est un exemple d'installation typique. Cependant, vous devez faire les ajustements correspondant à votre voiture particulière. Si vous avez des questions ou avez besoin d'information sur des kits d'installation, consulter votre revendeur d'autoradios JVC ou une compagnie d'approvisionnement.

- 1 Avant le montage:** Appuyer sur (déblocage du panneau de commande) pour éventuellement détacher le panneau de commande.  
\* Lorsque ce panneau de commande sort d'usine, il est rangé dans un étui de transport.
- Retirer la plaque d'assemblage.
- Libérer les verrous du manchon et retirer le manchon.
  - Poser l'appareil à la verticale.  
**Remarque:** Lorsque vous mettez l'appareil à la verticale, faire attention de ne pas endommager le fusible situé sur l'arrière.
  - Insérer les 2 poignées entre l'appareil et le manchon comme indiqué pour désengager les verrous de manchon.
  - Retirer le manchon.  
**Remarque:** S'assurer de garder les poignées pour une utilisation ultérieure, après l'installation de l'appareil.
- Installer le manchon dans le tableau de bord.  
\* Après installation correcte du manchon dans le tableau de bord, plier les bonnes pattes pour maintenir fermement le manchon en place, comme montré.
- Monter le boulon de montage sur l'arrière du corps de l'appareil puis passer l'amortisseur en caoutchouc sur l'extrémité du boulon.
- Réalisez les connexions électriques.
- Faites glisser l'appareil dans le manchon jusqu'à ce qu'il soit verrouillé.
- Attachez la plaque d'ajustage.  
**Remarque:** Assurez-vous que la partie encastrée est en bas. Sinon, le panneau de commande ne pourra pas être ouvert complètement.
- Remonter le panneau de commande.

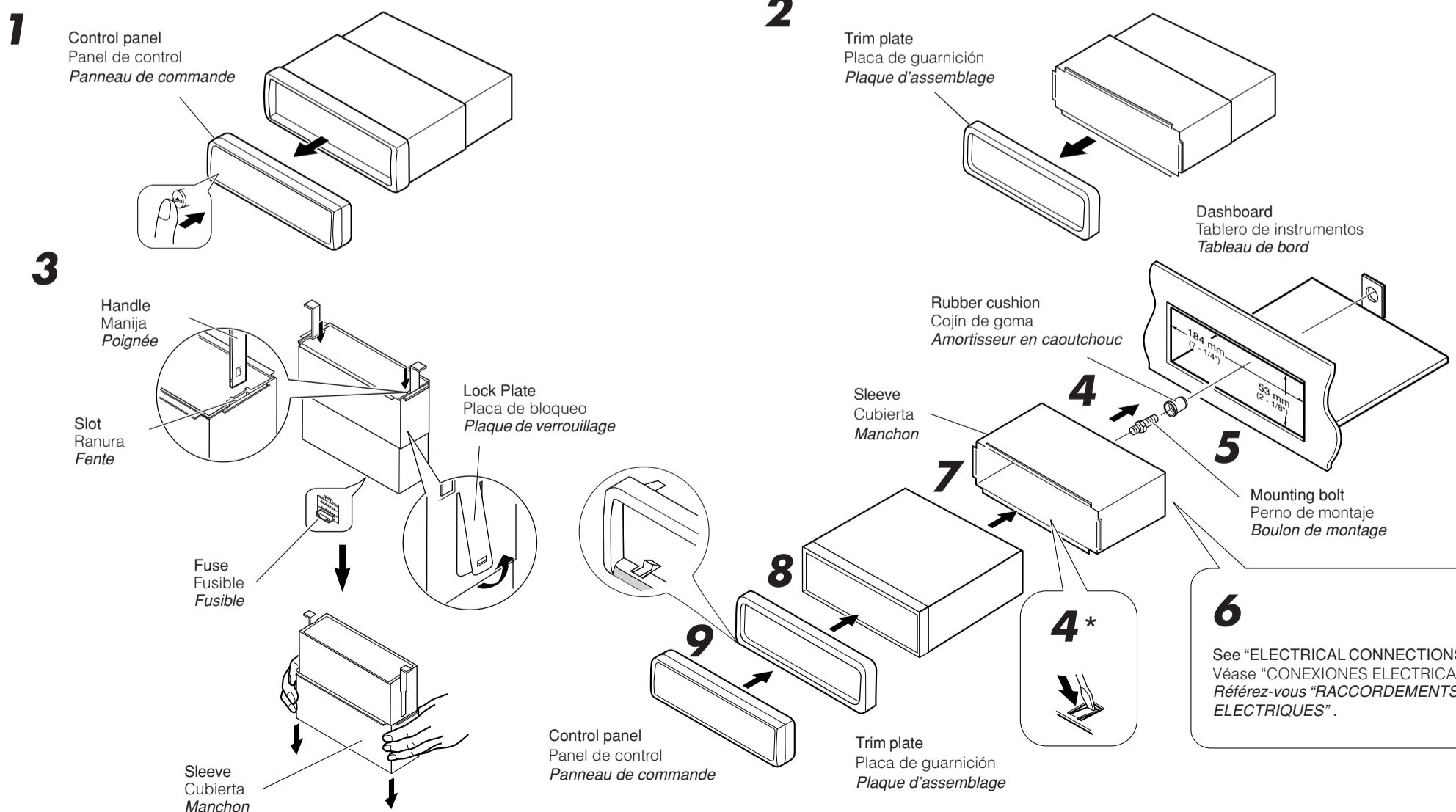



- When using the optional stay
- Cuando emplea un soporte opcional
- Lors de l'utilisation du hauban en option

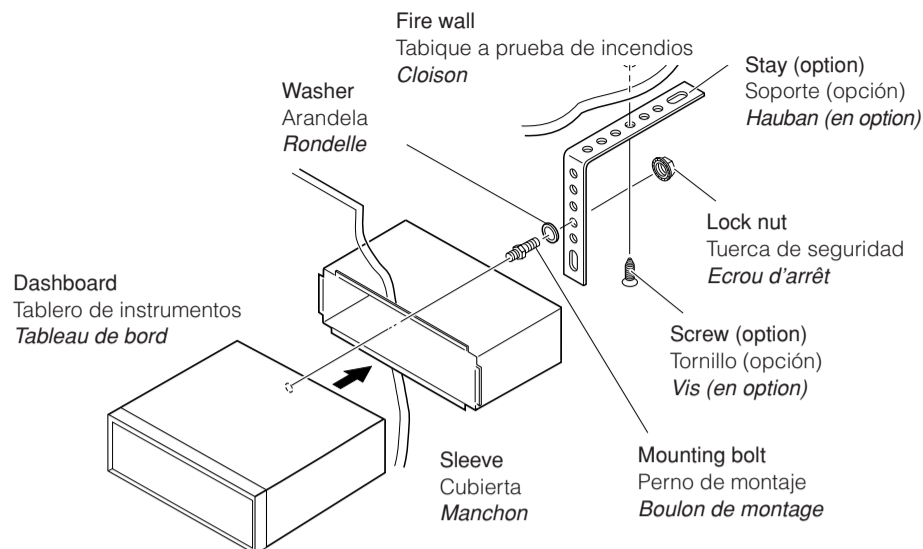

Less than 30°  
Menos de 30°  
Moins de 30°

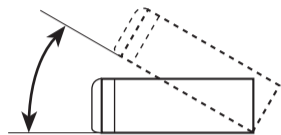

Install the unit at an angle of less than 30°  
Instale la unidad a un ángulo de menos de 30°  
Installez l'appareil avec un angle de moins de 30°

- When installing the unit without using the sleeve
- Instalación de la unidad sin utilizar la cubierta
- Lors de l'installation de l'appareil sans utiliser de manchon

In a Toyota for example, first remove the car radio and install the unit in its place.  
En un Toyota por ejemplo, primero extraiga la radio del automóvil y luego instale la unidad en su lugar.  
Par exemple dans une Toyota, retirer d'abord l'autoradio et installer l'appareil à la place.

Flat type screws M5 x 8 mm (M5 x 3/8")\*  
Tornillos tipo plano M5 x 8 mm (M5 x 3/8 pulgada)\*  
Vis à tête plate M5 x 8 mm (M5 x 3/8 pouces)\*

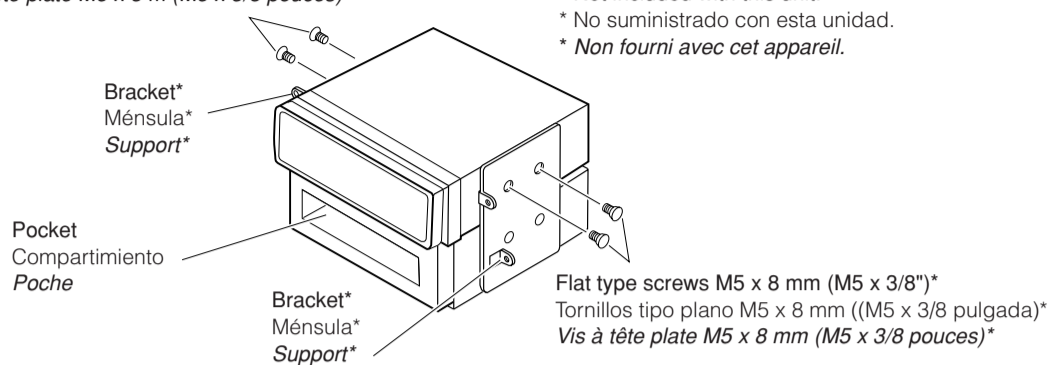

\* Not included with this unit.  
\* No suministrado con esta unidad.  
\* Non fourni avec cet appareil.

**Note:** When installing the unit on the mounting bracket, make sure to use the 8 mm (3/8")-long screws. If longer screws are used, they could damage the unit.

**Nota:** Cuando instala la unidad en la ménsula de montaje, asegúrese de utilizar los tornillos de 8 mm (3/8 pulgada) de longitud. Si se utilizan tornillos más largos, éstos pueden dañar la unidad.

**Remarque:** Lors de l'installation de l'appareil sur le support de montage, s'assurer d'utiliser des vis d'une longueur de 8 mm (3/8 pouces). Si des vis plus longues sont utilisées, elles peuvent endommager l'appareil.

### Removing the unit

- Before removing the unit, release the rear section.
- 1 Remove the control panel.
- 2 Remove the trim plate.
- 3 Insert the 2 handles into the slots, as shown. Then, while gently pulling the handles away from each other, slide out the unit. (Be sure to keep the handles after installing it.)

### Extracción de la unidad

- Antes de extraer la unidad, libere la sección trasera.
- 1 Extraiga el panel de control.
- 2 Retire la placa de guarnición.
- 3 Inserte las 2 manijas entre las ranuras, como se muestra. Luego, separe suavemente las manijas y extraiga la unidad. (Asegúrese de conservar las manijas después de instalarlo.)

### Retrait de l'appareil

- Avant de retirer l'appareil, libérer la section arrière.
- 1 Retirer le panneau de commande.
- 2 Retirer la plaque d'assemblage.
- 3 Introduire les deux poignées dans les fentes, comme montré. Puis, tout en tirant doucement les poignées écartées, faire glisser l'appareil pour le sortir. (S'assurer de conserver les poignées après l'installation de l'appareil.)

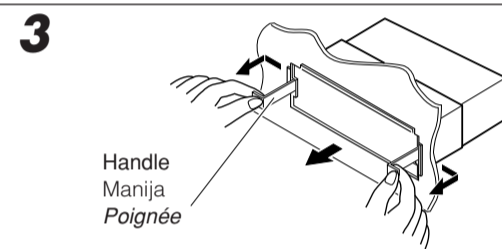
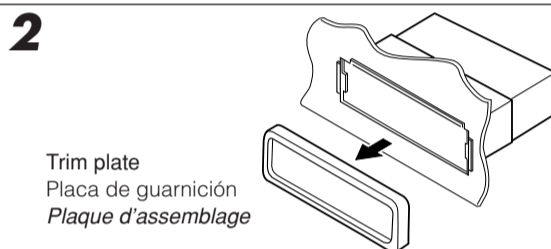
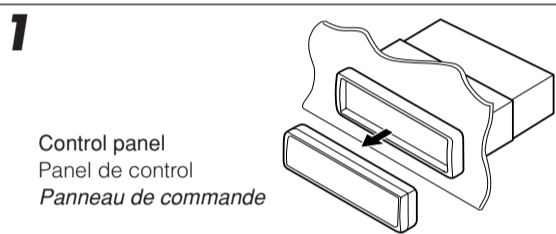

### Parts list for installation and connection

The following parts are provided with this unit.  
After checking them, please set them correctly.

### Lista de piezas para instalación y conexión

Con esta unidad se suministran las siguientes piezas.  
Después de inspeccionarlas, colóquelas correctamente.

### Liste des pièces pour l'installation et raccordement

Les pièces suivantes sont fournies avec cet appareil.  
Après vérification, veuillez les placer correctement.

Hard case/Control panel  
Estuche duro/Panel de control  
Etui de transport/Panneau de commande

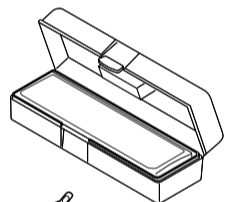

Sleeve  
Cubierta  
Manchon

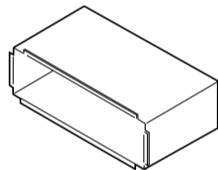

Trim plate  
Placa de guarnición  
Plaque d'assemblage

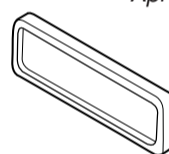

Remote controller  
Control remoto  
Télécommande



Battery  
Pila  
Pile  
CR2025



Power cord  
Cordón de alimentación  
Cordon d'alimentation

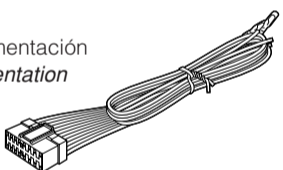

Handles  
Manijas  
Poignées



Washer (ø5)  
Arandela (ø5)  
Rondelle (ø5)



Lock nut (M5)  
Tuerca de seguridad (M5)  
Ecrou d'arrêt (M5)



Mounting bolt M5 x 20 mm (M5 x 13/16")  
Perno de montaje M5 x 20 mm (M5 x 13/16 pulgada)  
Boulon de montage M5 x 20 mm (M5 x 13/16 pouces)

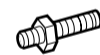

Rubber cushion  
Cojin de goma  
Amortisseur en caoutchouc



See page 30 - 31 of the Instructions for the usage of the following parts.

Con respecto al uso de las siguientes piezas, consulte la página 30 - 31 de las instrucciones.

Référez-vous à la page 30 - 31 du mode d'emploi pour savoir comment utiliser les pièces suivantes.

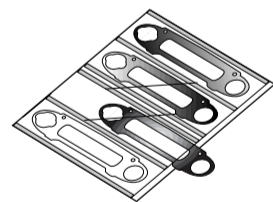

Additional standard plates (3)  
and transparent plate (1)  
Placas estándar adicionales (3)  
y placa transparente (1)  
Plaques standards  
additionnelles (3) et plaque  
transparente (1)

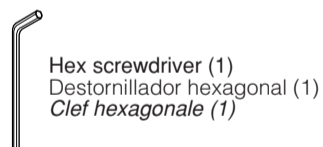

Hex screwdriver (1)  
Destornillador hexagonal (1)  
Clef hexagonale (1)

Spare screws for the plate cover attachment  
—M2 x 5 mm (M2 x 1/4") (2)  
Tornillos de repuesto para fijación de la placa de cubierta  
—M2 x 5 mm (M2 x 1/4 pulgada) (2)  
Vis de rechange pour la fixation du couvercle de la plaque  
—M2 x 5 mm (M2 x 1/4 pouces) (2)



Cutout plates (printed on the sheet) (4)  
Placas recortadas (impresas en la hoja) (4)  
Plaques découpées (imprimées sur une  
feuille) (4)

## ELECTRICAL CONNECTIONS

To prevent short circuits, we recommend that you disconnect the battery's negative terminal and make all electrical connections before installing the unit. If you are not sure how to install this unit correctly, have it installed by a qualified technician.

### Note:

This unit is designed to operate only on 12 V DC, NEGATIVE ground electrical systems. If your vehicle does not have this system, a voltage inverter is required, which can be purchased at JVC car audio dealers.

- Replace the fuse with one of the specified rating. If the fuse blows frequently, consult your JVC car audio dealer.
- If noise is a problem... This unit incorporates a noise filter in the power circuit. However, with some vehicles, clicking or other unwanted noise may occur. If this happens, connect the unit's rear ground terminal (see connection diagram) to the car's chassis using shorter and thicker cords, such as copper braiding or gauge wire. If noise still persists, consult your JVC car audio dealer.
- It is recommended to connect to the speakers with maximum power of more than 50 W (both at the rear and at the front, with an impedance of 4 Ω to 8 Ω). If the maximum power is less than 50 W, change "AMP GAIN" setting to prevent the speakers from being damaged (see page 28 of the INSTRUCTIONS).
- Be sure to ground this unit to the car's chassis.
- The heat sink becomes very hot after use. Be careful not to touch it when removing this unit.

Heat sink  
Sumidero térmico  
Dissipateur de chaleur

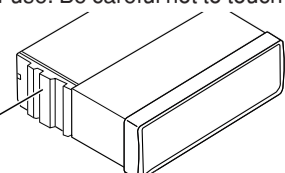

## CONEXIONES ELECTRICAS

Para evitar cortocircuitos, recomendamos que desconecte el terminal negativo de la batería y que efectúe todas las conexiones eléctricas antes de instalar la unidad. Si usted no está seguro de cómo instalar correctamente la unidad, hágala instalar por un técnico cualificado.

### Nota:

Esta unidad está diseñada para funcionar con 12 V de CC, con sistemas eléctricos de masa NEGATIVA solamente. Si su vehículo no posee este sistema, será necesario un inversor de tensión, que puede ser adquirido en los concesionarios de JVC de equipos de audio para automóviles.

- Reemplace el fusible por uno con la corriente especificada. Si el fusible se quemase frecuentemente consulte con su concesionario de JVC de equipos de audio para automóviles.
- Si el ruido fuese un problema... Esta unidad tiene un filtro de ruido en el circuito de alimentación. Sin embargo, en algunos vehículos, pueden producirse chasquidos u otros ruidos indeseados. En tal caso conecte el terminal de tierra posterior (véase diagrama de conexión) del receptor al chasis del automóvil, utilizando cordones más gruesos y cortos tales como alambre de cobre trenzado o de grueso calibre. Si el ruido persiste, consulte a su concesionario de JVC de equipos de audio para automóvil.
- Se recomienda conectar los altavoces con una potencia máxima de más de 50 W (tanto atrás como adelante, con una impedancia de 4 Ω a 8 Ω). Si la potencia máxima es de menos de 50 W, cambie "AMP GAIN" para evitar daños en los altavoces (consulte la página 28 del MANUAL DE INSTRUCCIONES).
- Asegúrese de conectar esta unidad a tierra en el chasis del automóvil.
- El sumidero térmico estará muy caliente después del uso. Asegúrese de no tocarlo al desmontar esta unidad.

## RACCORDEMENTS ELECTRIQUES

Pour éviter tout court-circuit, nous vous recommandons de débrancher la borne négative de la batterie et d'effectuer tous les raccordements électriques avant d'installer l'appareil. Si l'on n'est pas sûr de pouvoir installer correctement cet appareil, le faire installer par un technicien qualifié.

### Remarque:

Cet appareil est conçu pour fonctionner sur des sources de courant continu de 12 V à masse NEGATIVE seulement. Si votre véhicule n'offre pas ce type d'alimentation, il vous faut un convertisseur de tension, que vous pouvez acheter chez un revendeur d'autoradios JVC.

- Remplacer le fusible par un de la valeur précisée. Si le fusible saute souvent, consulter votre revendeur d'autoradios JVC.
- Si le bruit est un problème... Cet appareil incorpore un filtre de bruit dans le circuit d'alimentation. Cependant, avec certains véhicules, quelques claquements ou autres bruits non désirés risquent de se produire. Si cela arrive, raccorder la borne arrière de masse de l'appareil au châssis de la voiture (voir le schéma de raccordement) en utilisant des cordons les plus gros et les plus courts possibles telle qu'une barre de cuivre ou une tresse. Si le bruit persiste, consulter votre revendeur d'autoradios JVC.
- Il est recommandé de connecter des enceintes avec une puissance de plus de 50 W (les enceintes arrière et les enceintes avant, avec une impédance comprise entre 4 Ω et 8 Ω). Si la puissance maximum est inférieure à 50 W, changez "AMP GAIN" pour éviter d'endommager vos enceintes (voir page 28 du MANUEL D'INSTRUCTIONS).
- S'assurer de raccorder la mise à la masse de cet appareil au châssis de la voiture.
- Le dissipateur de chaleur devient très chaud après usage. Faire attention de ne pas le toucher en retirant cet appareil.



**A Typical Connections / Conexiones típicas / Raccordements typiques**

**Before connecting:** Check the wiring in the vehicle carefully not to fail in connecting this unit. Incorrect connection may cause a serious damage to this unit. The leads of the power cord and those of the connector from the car body may be different in color.

**Antes de la conexión:** Verifique atentamente el conexionado del vehículo para no cometer errores al conectar esta unidad. Una conexión incorrecta podría producir daños graves en la unidad. Los cordones del cable de alimentación y los del conector procedentes de la carrocería del automóvil podrían ser de diferentes en color.

**Avant de commencer la connexion:** vérifiez attentivement le câblage du véhicule pour ne pas connecter incorrectement cet appareil. Une connexion incorrecte peut endommager sérieusement l'appareil. Le fil du cordon d'alimentation et ceux des connecteurs du châssis de la voiture peuvent être différents en couleur.

**1** Connect the colored leads of the power cord to the car battery, speakers and automatic antenna (if any) in the following sequence.

**1** Conecte los conductores de color del cable de alimentación a la batería del automóvil, altavoces y antena automática (si la hubiere) en la secuencia siguiente.

**1** Connectez les fils de couleur du cordon d'alimentation à la batterie de la voiture, aux enceintes et à l'antenne automatique (s'il y en a une) dans l'ordre suivant.

- ① Black: ground
- ② Yellow: to car battery (constant 12 V)
- ③ Red: to an accessory terminal
- ④ Blue with white stripe: to remote lead of other equipment or automatic antenna if any (200 mA max.)
- ⑤ Orange with white stripe: to car light control switch
- ⑥ Others: to speakers

- ① Negro: a tierra
- ② Amarillo: a la batería del automóvil (12 V constantes)
- ③ Rojo: a un terminal de accesorio
- ④ Azul con rayas blancas: al conductor remoto de otro equipo o de la antena automática, si hubiere (máx. 200 mA)
- ⑤ Naranja con rayas blancas: al interruptor de control de las luces del automóvil
- ⑥ Otros: a los altavoces

- ① Noir: a la masse
- ② Jaune: a la batterie de la voiture (12 V constant)
- ③ Rouge: à la prise accessoire
- ④ Bleu avec bande blanche: au fil de télécommande de l'autre appareil ou à l'antenne automatique s'il y en a une (200 mA max.)
- ⑤ Orange avec bande blanche: à l'interrupteur d'éclairage de la voiture
- ⑥ Autres fils: aux enceintes

**2** Connect the antenna cord.

**2** Conecte el cable de antena.

**2** Connectez le cordon d'antenne.

**3** Finally connect the wiring harness to the unit.

**3** Por último, conecte a la unidad el cableado preformado.

**3** Finalement, connectez le faisceau de fils à l'appareil.

**CAUTION/PRECAUTION/ATTENTION:**

- Before connecting the CD changer, make sure that the unit is turned off. (only for KD-AR600)
- Antes de conectar el cambiador de CD, asegúrese de que la unidad está apagada. Sólo para KD-AR600
- Avant de connecter le changeur CD, assurez-vous que mettre l'appareil hors tension. Seulement pour le KD-AR600

We recommend you to connect the JVC MP3-compatible CD changer. You can also connect other CH-X series CD changers (except CH-X99 and CH-X100). You cannot use the KD-MK series CD changers with this unit. You can also use an external component such as a portable MD player by connecting the Line Input Adapter KS-U57 (not supplied). (See diagram B.)  
Se recomienda conectar el cambiador de CD de JVC compatible con MP3. También se pueden conectar otros cambiadores de CD de la serie CH-X (excepto CH-X99 y CH-X100). Conectando el adaptador de entrada de línea KS-U57 (no suministrado), también podrá usar un componente exterior, tal como un reproductor de MD. (Véase diagrama B.)  
Nous vous recommandons de connecter le changeur de CD compatible MP3 JVC. Vous pouvez aussi connecter d'autres changeurs de CD de la série CH-X (sauf le CH-X99 et le CH-X100). Vous ne pouvez pas utiliser les changeurs de CD de la série KD-MK avec cet appareil. Vous pouvez aussi utiliser un appareil extérieur tel qu'un lecteur de MD en connectant l'adaptateur d'entrée de ligne KS-U57 (non fourni). (voir le diagramme B.)

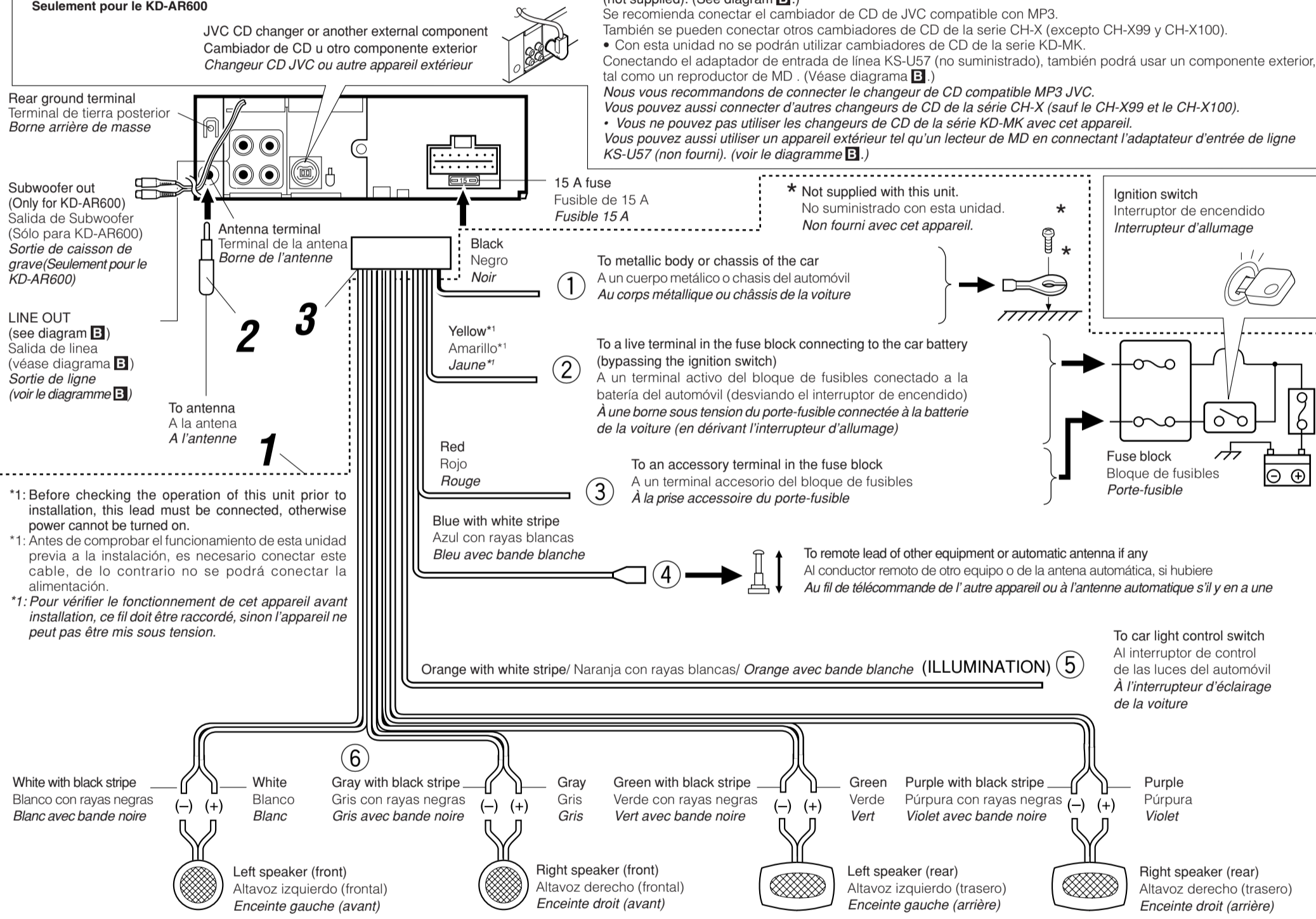

**PRECAUTIONS on power supply and speaker connections:**

- DO NOT connect the speaker leads of the power cord to the car battery; otherwise, the unit will be seriously damaged.
- Connect the black lead (ground), yellow lead (to car battery, constant 12 V), and red lead (to an accessory terminal) correctly.
- BEFORE connecting the speaker leads of the power cord to the speakers, check the speaker wiring in your car.
  - If the speaker wiring in your car is as illustrated in Fig. 1 and Fig. 2 below, DO NOT connect the unit using that original speaker wiring. If you do, the unit will be seriously damaged. Redo the speaker wiring so that you can connect the unit to the speakers as illustrated in Fig. 3.
  - If the speaker wiring in your car is as illustrated in Fig. 3, you can connect the unit using the original speaker wiring in your car.
  - If you are not sure of the speaker wiring of your car, consult your car dealer.

**PRECAUCIONES sobre las conexiones de la fuente de alimentación y de los altavoces:**

- NO conecte los conductores de altavoz del cable de alimentación a la batería de automóvil, pues podrían producirse graves daños en la unidad.
- Conecte correctamente el conductor negro (a tierra), el conductor amarillo (a la batería del automóvil, 12 V constantes), y el conductor rojo (a un terminal de accesorio).
- ANTES de conectar a los altavoces los conductores de altavoz del cable de alimentación, verifique el conexionado de altavoz de su automóvil.
  - Si el conexionado de altavoz de su automóvil es como se indica en las Fig. 1 y Fig. 2 de abajo, NO conecte la unidad utilizando ese conexionado de altavoz original. Si lo hace, se producirán daños graves en la unidad. Vuelva a efectuar el conexionado de altavoz de manera que pueda conectar la unidad a los altavoces de la manera indicada en la Fig. 3.
  - Si el conexionado de altavoz de su automóvil es como se indica en la Fig. 3, podrá conectar la unidad utilizando el conexionado de altavoz original de su automóvil.
  - Si tiene dudas sobre el conexionado de altavoz de su automóvil, consulte con su concesionario.

**PRECAUTIONS sur l'alimentation et la connexion des enceintes:**

- NE CONNECTEZ PAS les fils d'enceintes du cordon d'alimentation à la batterie; sinon, l'appareil serait sérieusement endommagé.
- Connectez correctement le fil noir (a la masse), le fil jaune (a la batterie de la voiture, 12 V constant) et le fil rouge (à la prise accessoire).
- AVANT de connecter les fils d'enceintes du cordon d'alimentation aux enceintes, vérifiez le câblage des enceintes de votre voiture.
  - Si le câblage des enceintes de votre voiture est réalisé comme montré sur la Fig. 1 ou Fig. 2 ci-dessous, NE CONNECTEZ PAS l'appareil en utilisant ce câblage original d'enceintes. Si vous le faites, l'appareil sera sérieusement endommagé. Recommencez le câblage des enceintes de façon que vous puissiez connecter l'appareil aux enceintes comme montré sur la Fig. 3.
  - Si le câblage des enceintes de votre voiture est comme montré sur la Fig. 3, vous pouvez connecter l'appareil en utilisant ce câblage original d'enceintes pour votre voiture.
  - Si vous n'êtes pas sûrs du câblage d'enceintes de votre voiture, consultez le concessionnaire de votre voiture.

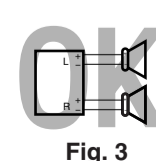
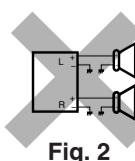
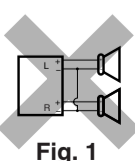

Fig. 1

Fig. 2

Fig. 3

## Connecting the leads / Conexión de los conductores / Raccordement des fils

Twist the core wires when connecting.  
Retuerza los alambres de alma para conectarlos.  
Torsader les âmes des fils en les raccordant.

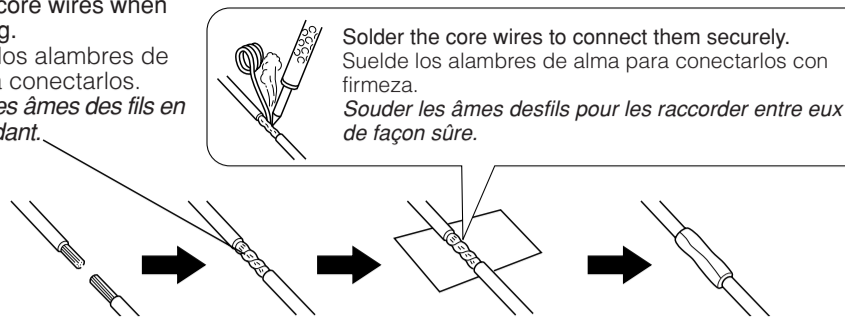

### CAUTION / PRECAUCION / PRECAUTION:

- To prevent short-circuit, cover the terminals of the UNUSED leads with insulating tape.
- Para evitar cortocircuitos, cubra los cables NO UTILIZADOS con cinta aislante.
- Pour éviter les court-circuits, couvrir les bornes des fils qui ne sont PAS utilisés avec de la bande isolante.

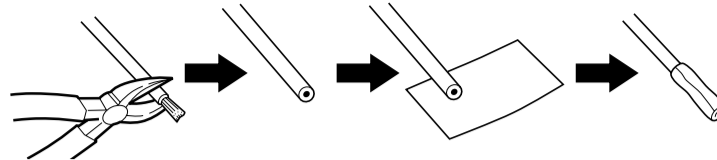

## B Connections Adding Other Equipment / Conexiones para añadir otros equipos / Raccordement pour ajouter d'autres appareils

### Amplifier / Amplificador / Amplificateur

You can connect an amplifier and other equipment to upgrade your car stereo system.

- Connect the remote lead (blue with white stripe) to the remote lead of the other equipment so that it can be controlled through this unit.
- Connect this unit's line-out terminals to the amplifier's line-in terminals.
- Disconnect the speakers from this unit, connect them to the amplifier. Leave the speaker leads of this unit unused. (Cover the terminals of these unused leads with insulating tape, as illustrated above.)**
- Only for KD-AR600: The line output level of this unit is kept high to maintain the hi-fi sounds reproduced from this unit.

**When connecting an external amplifier to this unit, turn down the gain control on the external amplifier to obtain the best performance from this unit.**

Usted podrá conectar un amplificador y otros equipos para mejorar el sistema estereo de su automóvil.

- Conecte el conductor remoto (azul con rayas blancas) al conductor remoto del otro equipo para poderlo controlar a través de esta unidad.
- Conecte los terminales de salida de línea de esta unidad a los terminales de entrada de línea del amplificador.
- Desconecte los altavoces de esta unidad y conéctelos al amplificador. Deje los conductores de los altavoces de esta unidad sin usar. (Recubrir los extremos de estos cables sin usar con cinta aislante como se muestra en la figura de arriba.)**
- Sólo para KD-AR600: El nivel de salida de línea de esta unidad se mantiene a un nivel elevado para mantener una calidad Hi-Fi para los sons reproducidos por este aparato.

**Lors de la connexion d'un amplificateur extérieur à cet appareil, diminuez le réglage du gain sur l'amplificateur extérieur pour obtenir les meilleures performances de cet appareil.**

Vous pouvez connecter un amplificateur ou autre appareil pour améliorer votre système autoradio.

- Connectez le fil de commande à distance (bleu avec bande blanche) au fil de commande à distance de l'autre appareil de façon qu'il puisse être commandé via cet appareil.
- Raccordez les fiches de sortie ligne de cet appareil aux fiches d'entrée ligne de l'amplificateur.
- Déconnectez les enceintes de cet appareil et connectez-les à l'amplificateur. Laissez les fils d'enceintes de cet appareil inutilisés. (Cubra los terminales de estos cables sin usar con cinta aislante, tal comose indica en la figura de arriba.)
- Seulement pour le KD-AR600: Le niveau de sortie de ligne de cette unité demeure élevé pour correspondre aux sons de haute fidélité reproduits par cette unité.

**Quando conecte un amplificador externo a esta unidad, disminuya el control de ganancia del amplificador externo para obtener un óptimo rendimiento de esta unidad.**

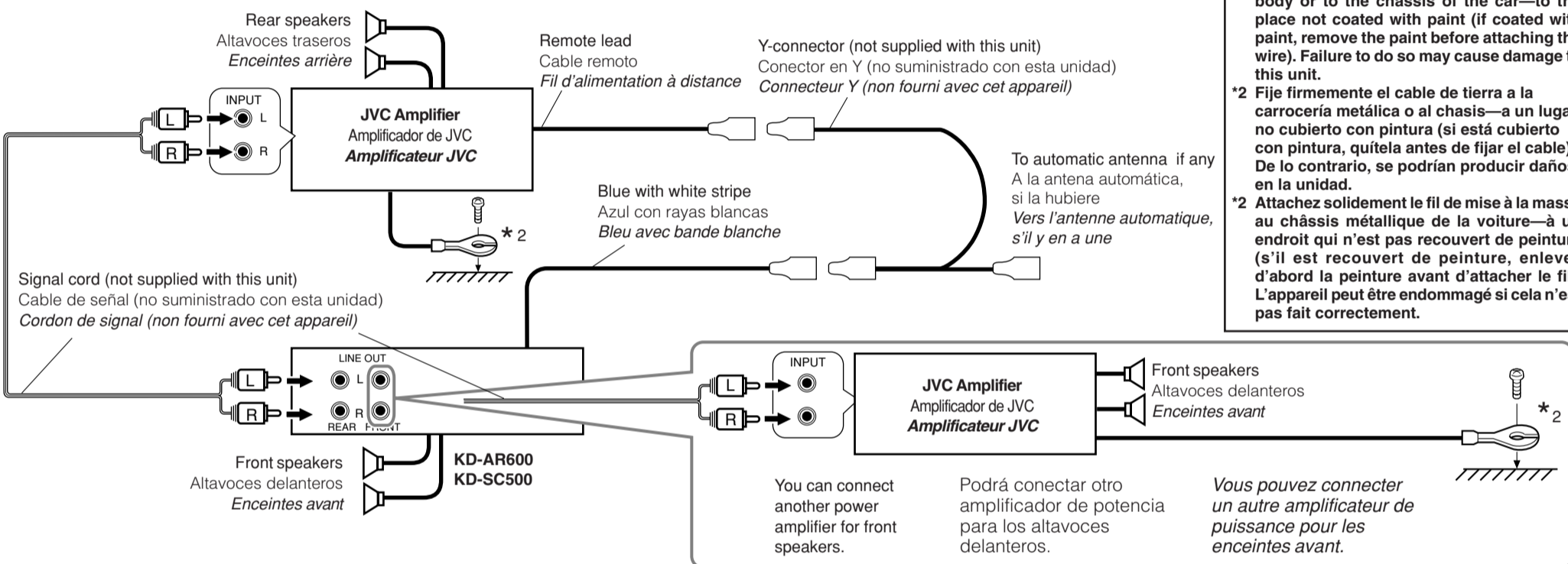

## Subwoofer (Subwoofer out) / Subwoofer (Salida de Subwoofer) / Caisson de grave (Sortie de caisson de grave)

### Only for KD-AR600:

You can connect a subwoofer through an amplifier to reinforce the bass.

- For their connections, refer to the instructions supplied with your subwoofer.

### Sólo para KD-AR600:

Usted podrá conectar un subwoofer a través de un amplificador para reforzar los graves.

- Con respecto a sus conexiones, refiérase a las instrucciones suministradas con sus subwoofer.

### Seulement pour le KD-AR600:

Vous pouvez connecter un caisson de grave par un amplificateur pour renforcer les graves.

- Pour la connexion, référez-vous aux instructions fournies avec le caisson de grave.

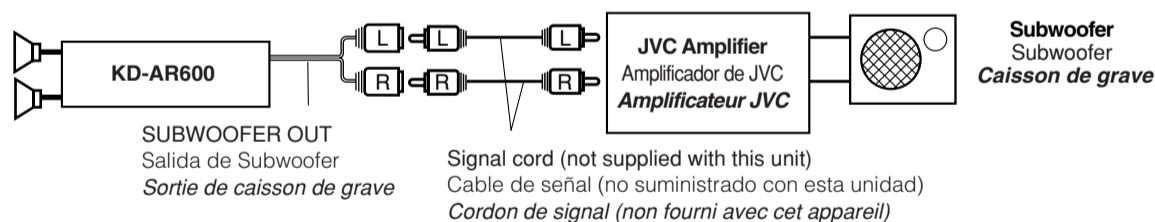

## External component / Componente exterior / Appareil extérieur

For connecting the JVC SIRIUS Radio, refer to the SIRIUS Radio Setup Manual (separate volume).

Para la conexión de la radio JVC SIRIUS, consulte el Manual de configuración de la radio SIRIUS (volumen separado).

Pour brancher la radio JVC SIRIUS, référez-vous au Manuel d'installation de la radio SIRIUS (volume séparé).

### Only for KD-AR600

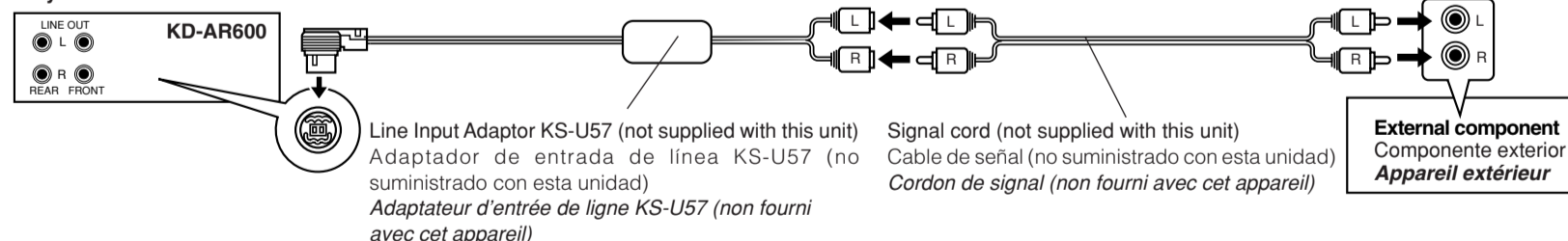

## TROUBLESHOOTING

### The fuse blows.

\* Are the red and black leads connected correctly?

### Power cannot be turned on.

\* Is the yellow lead connected?

### No sound from the speakers.

\* Is the speaker output lead short-circuited?

### Sound is distorted.

\* Is the speaker output lead grounded?

\* Are the “-” terminals of L and R speakers grounded in common?

### Unit becomes hot.

\* Is the speaker output lead grounded?

\* Are the “-” terminals of L and R speakers grounded in common?

## LOCALIZACION DE AVERIAS

### El fusible se quema.

\* ¿Están los conductores rojo y negro correctamente conectados?

### No es posible conectar la alimentación.

\* ¿Está el cable amarillo conectado?

### No sale sonido de los altavoces.

\* ¿Está el cable de salida del altavoz cortocircuitado?

### El sonido presenta distorsión.

\* ¿Está el cable de salida del altavoz conectado a masa?

\* ¿Están los terminales “-” de los altavoces L y R conectados a una masa común?

### La unidad se calienta.

\* ¿Está el cable de salida del altavoz conectado a masa?

\* ¿Están los terminales “-” de los altavoces L y R conectados a una masa común?

## EN CAS DE DIFFICULTES

### Le fusible saute.

\* Les fils rouge et noir sont-ils raccordés correctement?

### L'appareil ne peut pas être mise sous tension.

\* Le fil jaune est-elle raccordée?

### Pas de son des enceintes.

\* Le fil de sortie de d'enceinte est-il court-circuité?

### Le son est déformé.

\* Le fil de sortie de d'enceinte est-il à la masse?

\* Les bornes “-” des enceintes gauche et droit sont-elles mises ensemble à la masse?

### L'appareil devient chaud.

\* Le fil de sortie de d'enceinte est-il à la masse?

\* Les bornes “-” des enceintes gauche et droit sont-elles mises ensemble à la masse?